

- Hydraulic Pullers, Tensioners, Puller/Tensioners & Winches
- Fixed Joints, Swivels, Grip & Socks
- Reel Winders, Drum Elevators & Stands
- Reels, Anti-Twist Steel & Dyneema Ropes
- OPGW Installation Equipment
- Stringing Rollers & Blocks
- Balancing Headboards
- Conductor Chairs & Cars
- Suspension Ladders & Working Platforms

# TRANSMISSION STRINGING

## TRANSMISSION STRINGING - TABLE OF CONTENTS

TESMEC Stringing Machines.....	J4	Drum Stand .....	J22
Digital Human Interface (HMI).....	J4	Heavy Duty Drum Stand .....	J22
Digital Stringing Machines Main Features .....	J5	Standard Reel Adaptor .....	J23
Re.M (REMOTE MONITORING SYSTEM) .....	J6	Drum Supports .....	J23
Digital Hydraulic Pullers - TESMEC.....	J7	Hydraulic Hose Set.....	J23
100kN Digital Puller .....	J7	Hydraulic Motor - Reel Winder.....	J23
160kN Digital Puller.....	J8	Auto Rope Leveler .....	J23
180kN Digital Puller.....	J9	Hydraulic Pressure Relief Kit .....	J23
Digital Hydraulic Tensioners - TESMEC .....	J10	Reels - TESMEC .....	J24
80kN Digital Tensioner .....	J10	Standard Fixed Reels.....	J24
140kN Digital Tensioner .....	J11	Cross Support .....	J24
Digital Hydraulic Puller Tensioners - TESMEC.....	J12	Detachable Reels.....	J25
50kN Digital Puller Tensioner.....	J12	Ropes .....	J25
100kN Digital Puller Tensioner.....	J13	Anti Twisting Steel Braided Rope Standard - TESMEC .....	J25
140kN/160kN Digital Puller Tensioners.....	J14	Double Braided Hauling Rope - Hampidjan.....	J26
Digital Tensioner - Helicopter stringing - TESMEC.....	J15	Robus Dyneema Rope - Hampidjan .....	J26
30kN Hydraulic Tensioner.....	J15	Polypropylene Rope 3 Strand - Hampidjan.....	J26
Continuous Line Pullers - TESMEC.....	J16	Fixed Joints, Swivels, Grips and Socks.....	J27
50kN Continuous Line Puller .....	J16	Fixed Joint - TESMEC .....	J27
50kN Continuous Line Puller .....	J17	Swivel Joint - TESMEC .....	J27
Equipment Winches - TESMEC.....	J18	Heavy Duty Large Eye Conductor Socks - TESMEC.....	J28
30kN Drum Winches .....	J18	Heavy Duty Conductor Double Head Sock - TESMEC .....	J28
50kN Drum Winches .....	J18	Radial Locking Clamps - TESMEC .....	J29
Hydraulic Pullers - TESMEC.....	J19	Grips - Riganti.....	J30
15kN Hydraulic Puller.....	J19	Liners - Riganti.....	J31
30kN Hydraulic Puller .....	J19	OPGW Installation - TESMEC.....	J32
35kN Hydraulic Puller .....	J20	Optical Earth Wire Anti-Torque Devices .....	J32
240 kN Hydraulic Puller.....	J20	Pulling Clamp For Fibre Optic .....	J32
Reel Winders, Drum Elevators and Stands - TESMEC.....	J21	Counterweight Device for stringing OPGW Cables .....	J32
Reel Winders.....	J21	Traction Machine.....	J33
Cradle Reel Elevators.....	J21	Recovery Device.....	J33
Hydraulic Drum Elevators - Heavy Duty.....	J22	Braking Device.....	J34
		OPGW Cradle Blocks.....	J34
		OPGW Cradle Blocks.....	J35

### TRANSMISSION STRINGING - TABLE OF CONTENTS

Stringing Rollers/Blocks and Pivoting Array Blocks .....	J36	Aluminium Structures.....	J49
Pivoting Array Blocks - TESMEC .....	J36	Working Platforms – Hiatco .....	J49
Universal Stringing Roller - SPP .....	J37	Working Platforms - TESMEC.....	J49
Single Convertible Roller/Block - SPP.....	J37	Anchoring Ladders - TESMEC.....	J50
Nylon Stringing Rollers/Blocks - TESMEC.....	J38	Suspension Ladders - TESMEC .....	J51
Single Nylon Stringing Blocks .....	J38	Double Swivel Ladder Hook - TESMEC .....	J51
Two or Three Bundled Conductor Nylon Stringing Block.....	J38	Anti-Fall Devices - TESMEC.....	J51
Four or Five Bundled Conductors Nylon Stringing Blocks .....	J38	Aluminium Derricks - TESMEC .....	J52
Stringing Roller/Block - SPP .....	J39	Support Structure - TESMEC.....	J53
Single Full Frame Roller/Block - SPP .....	J39	Monopole Ladders - TESMEC .....	J54
Fittings - Ball Clevis - SPP .....	J39	Support for working platform - TESMEC.....	J54
Ball Clevis Socket Fittings.....	J39	Horizontal Ladder - TESMEC.....	J54
Stringing Rollers/Blocks - TESMEC .....	J40	Transmission Overhead PPE, Tools & Accessories.....	J55
Single Stringing Roller/Block .....	J40	Conductor Lifter Hook.....	J55
Two or Three Bundled Conductor Stringing Blocks.....	J41	Rescue Kit - Tower .....	J55
Four & Five Bundled Conductor Stringing Blocks .....	J41	Wire Rope Slings 3.0T .....	J55
Detachable Two or Three Bundled Stringing Block .....	J42	Soft Round Slings.....	J55
Helicopter Stringing Block .....	J42	ACSR Strippers .....	J56
Helicopter Stringing Block .....	J43	Steel Service Snatch Blocks - TESMEC .....	J56
Helicopter Stringing Block .....	J43	Hand Line Blocks .....	J57
Tandem Stringing Roller/Blocks.....	J44	Anti-Lifting Automatic Release Pulley - TESMEC.....	J57
Earthing Devices for Stringing Blocks - TESMEC .....	J45	Lifting Tackles .....	J57
Anti-fleeting Devices - TESMEC .....	J45	Zoom Sag Scope - TESMEC .....	J58
Pivoting Array Blocks - TESMEC .....	J46	Thermometers - TESMEC.....	J58
Single Conductor Pivoting Array Blocks .....	J46	Cover Joints - TESMEC .....	J58
Two or Three Bundled Conductors Pivoting Array Blocks .....	J46	EPZ - (Equipotential Zone) .....	J59
Four or Five Conductors Pivoting Array Blocks .....	J46	Rolling / Running Earths .....	J59
Two or Three Conductors Pivoting Array Helicopter Blocks..	J46	Equipotential Earth Mats - Kri-Tech.....	J59
Head Boards - TESMEC .....	J47	PEDs - Portable Earthing Devices.....	J60
2 or 3 Conductors Fixed Head Boards .....	J47	Stick Kits - Hastings.....	J60
2, 3 or 4 Conductors Balancing Head Boards.....	J47	Shotgun Stick Kit .....	J60
Conductor Chairs & Cars.....	J48	Sectional Stick Kit .....	J60
Conductor Cars For Single Conductor Lines - TESMEC.....	J48	Conductor Triple Line Lifters - LineWise .....	J61
Conductor Spacer Chair – Hiatco.....	J48	Triple Line Lifter - Max 1770kg.....	J61
Inspection Conductor Car - TESMEC .....	J48	Triple Line Lifter - Max 3408kg .....	J61



## Tesmec Generation 4.0 machines with the Digital Human Interface



# TESMEC

**PT2451 - 100kN Digital Puller Tensioner**

### Digital Human Interface (HMI)

The digital HMI (Human Machine Interface) is a significant innovation on the 4.0 stringing machine. The control panel is drastically simplified.

The innovative graphic display shows all the information, including diesel engine parameters, machine performance, and diagnostic output.

This digital technology eliminates most of the instruments and devices installed on the previous control panel.

The remote operates up to a distance of 100m from the machine in line of site. It can also be connected by cable, both options give the operator full control of the machine in a position that offers a better overview of the worksite.

**Note:**

Pullers equipped with reel-winders feature automatic back-pull control for optimal performance and simple operation.



Full Function Remote Control



### Diagnostic Features

- Maintenance interval scheduling, with countdown and alerts.
- Machine alerts display errors with detailed description.
- Alerts recording option for authorised service inspection.
- Automatic self-diagnosis at machine start.

### Efficiency

- Automatic diesel engine rpm setting maximises stringing speed and offers better oil cooling and fuel savings.
- Automatic oil cooling according to oil viscosity.
- Reduce operator errors and maximise uptime.
- Analog Circular chart displays operating parameters and machine limits.
- Automatic cutting pressure device, to avoid any possible overload on the machine.

### Re.M. (Remote Monitoring System) - ALL270

Remote monitoring package for main performance and diagnostic parameters, including alarms and a GPS localization, available on request.

### Integrated Recorder

Integrated pull recorder stores the operational data. Downloadable using a simple USB flash drive. Printer also available as an option.

## Digital Stringing Machines Main Features



### Configuration

Full package in the standard version configuration.

The standard machine includes a complete package of devices:

- Integrated pull recorder.
- Radio remote control.
- Conductor clamp.
- Low range gearbox (50 kN range).

Range of available options include: preheating device for extra cold ambient temperatures, road transportation package, electronic connection of modular machines, remote diagnosis package and low range solution (100 kN range and higher).



### Power Unit

Diesel engine: Stage 4, tier 4f and Stage 5

Each machine is also available with engine equivalent to the previous Stage emission level for markets where ultra high grade fuel is not available.

Integral cover of the whole power unit and modularity in single components.

### Integral Cover

The integral cover of the whole power unit grants:

- Best protection of all the installed components.
- Reduction of noise emission.

Modular design and standardized components reduces spare parts and simplifies maintenance.

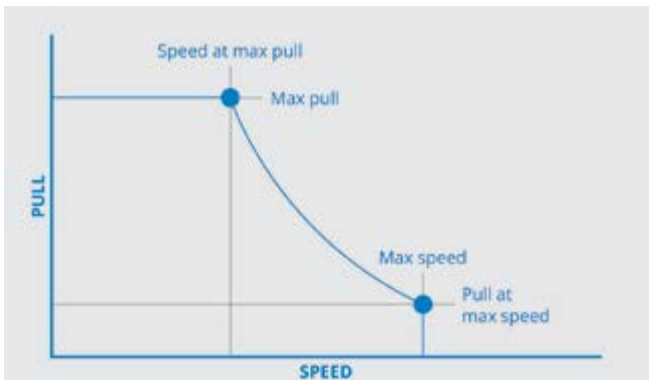

### Performance

#### Operating pull vs speed

Unique hydraulic circuit for stepless speed variation. Automatic management of the diesel engine for highest possible operating speed depending on work conditions.



### Mobility

#### Two travel configurations

The machine layout allows the installation of rigid or road axles configurations.

Road axle with EU type approved is available.

### Re.M (REMOTE MONITORING SYSTEM)

All you need to use Tesmec Re.M is an Internet connection and a browser!

The interface will give you all the machine information (engine parameters, pressures and temperatures), included the geofencing (GPS coordinates).

The remote monitoring system, RE.M, acquires, analyzes and manages information from our pullers, tensioners and puller-tensioners.

This system allows a fleet management time saving of 25%.

All the information is forwarded to a cloud platform through a data connection and is available using an Internet connection and browser.

The remote access option is the easiest way to check machine data. In case of failure, service technicians can obtain the situation analy before they reach the job-site reducing problem resolution and next step timing.



#### Daily Control Of All Machines

Data collected by RE.M allow a reduction of data processing errors and a daily fleet control through:

- Statistics of machine use
- Monitoring of operating parameters such as temperature, pressure of hydraulic system and working hours
- Monitoring machine status
- Monitoring of productivity

#### Proactive Maintenance Management

- Automatic acquisition of engine hours.
- Reduction of time dedicated to finding equipment for maintenance.
- Monitoring of machine status in order to prevent failure and to reduce downtime.

#### Geofencing

With RE.M you can define virtual fences that allow monitoring of machines' position on job-sites and whenever a machine is leaving a geofenced area the system sends a text message and/or an email that can help tracking and recovering the machine; reducing theft related costs.

#### Reliable Technical Assistance

Thanks to electronic error notification, RE.M simplifies problem resolution process, reducing troubleshooting and allowing speed and focused technical assistance with the possibility of problem resolution by remote.

#### System Availability

RE.M is available on all the digital stringing machines. Following customer authorisation, the system will be activated and data access will be possible through a customer private account. During machine warranty period, Tesmec S.p.A. can access and use all the data transmitted by RE.M for problems resolution or for maintenance. On request, the system can be installed on existing machines.

TEN Hire (SRT) offers 24/7 back-up repair and trouble shooting service. Maintenance and Repairs can be carried out on-site or at the TEN Hire facility.

See TEN Hire & SRT information at the end of the Transmission Stringing section.



**Digital Hydraulic Pullers - TESMEC**

**100kN Digital Puller**  
Part No. PL1450



MAX PULL

**100kN**



MAX SPEED

**4.5km/h**



ROPE DIAMETER

**21 mm**

- Tesmec Digital HMI  
178mm (7") Colour Display.  
Radio Remote Control.  
Data Recorder
- Automatic reel winder
- Integrated covers

**100kN**  
**MAX PULL**

Performance	
Max pull (kN)	100
Speed at Max pull (km/hr)	2.0
Max speed (km/hr)	4.5
Pull at Max speed (kN)	45

Characteristics	
Bull-wheel diameter (mm)	525
Bull-wheel material	STEEL
Max rope diameter (mm)	21
Weight (without rope) (kg)	4600
Number of grooves	9
Suitable for	1 rope
Layout	Single

Engine	
Diesel (kW)	105 (140hp)
Cooling System	Water
Electrical System	24V

Configuration
Automatic reel winder. On board automatic reel winder with level wind, for reel mod. BOF010 and BOF020. Reel shaft AXR001.

Available Options	
ALL037	Preheating device up to -30°C
ALL089	Electronic connection and synchronization between machines
ALL111	Swivel guide rope roller
ALL261	External printer
ALL270	Remote Diagnostic system with GPS localization including 3-year subscription
ALL280	Automatic grease pump
AXR001	Extra shaft

**Ideal for Green Field Construction**





## 160kN Digital Puller

Part No. PL1700



MAX PULL

160kN



MAX SPEED

4.5km/h



ROPE DIAMETER

28mm

- Tesmec Digital HMI  
178mm (7") Colour Display.  
Radio Remote Control.  
Data Recorder
- Automatic reel winder
- Integrated covers

**160kN**  
MAX PULL



Performance	
Max pull (kN)	160
Speed at max pull (km/hr)	2.8
Max speed (km/hr)	4.5
Pull at max speed (kN)	105

Hydraulic Transmission	
Closed hydraulic with pull pre-setting system that automatically adjust pulling speed.	

Characteristics	
Bull-wheel diameter (mm)	700
Bull-wheel material	STEEL
Max rope diameter (mm)	28
Weight (without rope) (kg)	7500
Number of grooves	10
Suitable for	1 rope
Layout	Single

Engine	
Diesel (kW)	210 (281hp)
Cooling System	Water
Electrical System	24V

Configuration	
Automatic reel winder. On board automatic reel winder with level wind, for reel mod. BOF020 and BOF030. Reel shaft AXR002.	

Available Options	
ALL037	Preheating device up to -30°C
ALL089	Electronic connection and synchronization between machines
ALL111	Swivel guide rope roller
ALL261	External printer
ALL280	Automatic grease pump
AXR002	Extra shaft
ALL010	Hydraulic power pack to control a separate reel winder
ALL022	Hydraulic quick connectors to control a separate reel winder instead of the built-in one

**Ideal for Green Field Construction**



7" COLOUR DISPLAY



RADIO REMOTE CONTROL



## 180kN Digital Puller

Part No. PL1750



MAX PULL

**180kN**



MAX SPEED

**4.5km/h**



ROPE DIAMETER

**28mm**

- Tesmec Digital HMI  
178mm (7") Colour Display.  
Radio Remote Control.  
Data Recorder
- Automatic reel winder
- Integrated covers

**180kN**  
**MAX PULL**



Performance	
Max pull (kN)	180
Speed at max pull (km/hr)	2.5
Max speed (km/hr)	4.5
Pull at max speed (kN)	105

Hydraulic Transmission	
Closed hydraulic with pull pre-setting system that automatically adjust pulling speed.	

Characteristics	
Bull-wheel diameter (mm)	700
Bull-wheel material	STEEL
Max rope diameter (mm)	28
Weight (without rope) (kg)	7500
Number of grooves	10
Suitable for	1 rope
Layout	Single

Engine	
Diesel (kW)	210 (281hp)
Cooling System	Water
Electrical System	24V

Configuration	
Automatic reel winder. On board automatic reel winder with level wind, for reel mod. BOF020 and BOF030. Reel shaft AXR002.	

Available Options	
ALL037	Preheating device up to -30°C
ALL089	Electronic connection and synchronization between machines
ALL111	Swivel guide rope roller
ALL261	External printer
ALL280	Automatic grease pump
AXR002	Extra shaft
ALL010	Hydraulic power pack to control a separate reel winder
ALL022	Hydraulic quick connectors to control a separate reel winder instead of the built-in one

**Ideal for Green Field Construction**



4490



2260



7" COLOUR DISPLAY



RADIO REMOTE CONTROL

## Digital Hydraulic Tensioners - TESMEC

### 80kN Digital Tensioner

Part No. TN2350



**MAX TENSION**  
2 x 40kN



**MAX SPEED**  
5km/h



**CONDUCTOR DIAMETER**  
42mm



- Tesmec Digital HMI  
178mm (7") Colour Display.  
Radio Remote Control.  
Data Recorder
- Automatic reel winder
- Integrated covers

**80kN  
MAX PULL**

Performance	
Max tension (kN)	2 x 40/ 1 x 80
Speed at max tension (km/hr)	3
Max speed (km/hr)	5
Max pull back (kN)	2 x 40/ 1 x 80

Hydraulic Transmission	
Half closed hydraulic circuit with tension presetting system.	

Characteristics	
Bull-wheel diameter (mm)	1500
Bull-wheel material	NYLON
Max conductor diameter (mm)	42
Max rope diameter (mm)	21
Weight (without rope) (kg)	7000
Number of grooves	12
Suitable for	2 conductors
Layout	Twin

Engine	
Diesel (kW)	55.4 (140hp)
Cooling System	Water
Electrical System	12V

Configuration	
Tesmec digital HMI. Lockable sound proof integrated covers. Rope clamp for reel change. Negative self-acting hydraulic brake. Rigid axle 30 km/h. Earthing connection point. Hydraulic front stabilizers. Power pack to control 2 reel stands or 2 reel-winders.	
Gearbox with 3 operating positions on 1 circuit:	
<ul style="list-style-type: none"> <li>• Neutral position (with free bull-wheels for conductor loading and unloading).</li> <li>• Low tension position (1 to 7 kN).</li> <li>• Nominal tension position.</li> </ul>	

Available Options	
ALL005	Hydraulic power for compressor
ALL037	Preheating device up to -30°C.
ALL089	Electronic connection and synchronization between machines.
ALL261	External printer
ALL270	Remote Diagnostic system with GPS localization including 3-year subscription.
ALL280	Automatic grease pump

**Ideal for Green Field Construction**



### 140kN Digital Tensioner

Part No. TN2600



MAX TENSION

2 x 70kN



MAX SPEED

5km/h



CONDUCTOR DIAMETER

51 mm

- Tesmec Digital HMI  
178mm (7") Colour Display.  
Radio Remote Control.  
Data Recorder
- Rope clamp
- Integrated covers

**140kN**  
**MAX PULL**

Performance	
Max tension (kN)	2 x 70/ 1 x 140
Speed at Max tension (km/hr)	3
Max speed (km/hr)	5
Pull at Max speed (kN)	2 x 70/ 1 x 140

Hydraulic Transmission	
Half closed hydraulic circuit with tension presetting system.	

Characteristics	
Bull-wheel diameter (mm)	1800
Bull-wheel material	NYLON
Max conductor diameter (mm)	51
Max rope diameter (mm)	25
Weight (without rope) (kg)	10000
Number of grooves	12
Suitable for	2 conductor
Layout	Twin

Engine	
Diesel (kW)	55.4 (140hp)
Cooling System	Water
Electrical System	12V

Configuration	
Tesmec digital HMI.	
Lockable sound proof integrated covers.	
Rope clamp for reel change.	
Negative self-acting hydraulic brake.	
Rigid axle 30 km/h.	
Earthing connection point.	
Hydraulic front stabilizers.	
Power pack to control 2 reel stands or 2 reel-winders.	

Available Options	
ALL005	Hydraulic power for compressor
ALL037	Preheating device up to -30°C
ALL087	Low tension device
ALL089	Electronic connection and synchronization between machines.
ALL261	External printer
ALL270	Remote Diagnostic system with GPS localization including 3-year subscription
ALL280	Automatic grease pump.

**Ideal for Green Field Construction**



7" COLOUR DISPLAY



RADIO REMOTE CONTROL



## Digital Hydraulic Puller Tensioners - TESMEC

### 50kN Digital Puller Tensioner Part No. PT1250



MAX TENSION

50kN



MAX SPEED

5km/h



CONDUCTOR DIAMETER

42mm

- Tesmec Digital HMI  
178mm (7") Colour Display.  
Radio Remote Control.  
Data Recorder
- Available for road use
- Integrated covers

**50kN  
MAX PULL**

Performance	
Max pull (kN)	50
Speed at Max pull (km/hr)	1.5
Max speed (km/hr)	5
Pull at Max speed (kN)	12

Hydraulic Transmission	
Closed hydraulic with pull pre-setting system that automatically adjust pulling speed.	

Characteristics	
Bull-wheel diameter (mm)	1500
Bull-wheel material	NYLON
Max conductor diameter (mm)	42
Max rope diameter (mm)	16
Weight (without rope) (kg)	3450
Number of grooves	6
Suitable for	1 rope/ conductor
Layout	Single

Engine	
Diesel (kW)	55.4 (74hp)
Cooling System	Water
Electrical System	12V

Configuration	
Tescmec digital HMI. Lockable sound proof integrated covers. Rope clamp for reel change. Negative self-acting hydraulic brake. Rigid axle 30 km/h. Earthing connection point. Hydraulic front stabilizers.	

Power pack to control 1 reel stand or 1 reel-winder.

- Gearbox with 3 operating positions on 1 circuit:
- Neutral position (with free bull-wheels for conductor loading and unloading).
  - Low tension position:
    - 2 to 12kN as tensioner
    - 0 to 7kN as puller
  - Nominal tension position.

Available Options	
ALL005	Hydraulic power for compressor
ALL037	Preheating device up to -30°C.
ALL080	Special kit for 2 conductors up to Ø 31mm.
ALL089	Electronic connection and synchronization between machines.
ALL261	External printer
ALL270	Remote Diagnostic system with GPS localization including 3-year subscription.
ALL280	Automatic grease pump

**Perfect for Construction and Reconductoring**

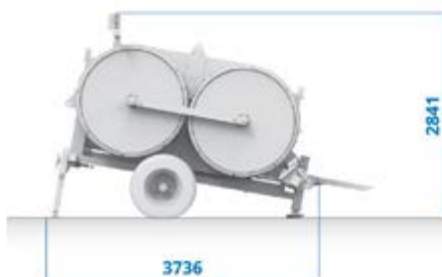

7" COLOUR DISPLAY



RADIO REMOTE CONTROL

### 100kN Digital Puller Tensioner

Part No. PT2451



MAX TENSION

2 x 50kN



MAX SPEED

5km/h



CONDUCTOR DIAMETER

42mm

- Tesmec Digital HMI  
178mm (7") Colour Display.  
Radio Remote Control.  
Data Recorder
- Rope clamp
- Integrated covers

**100kN**  
**MAX PULL**

Performance	
Max pull (kN)	2 x 50/ 1 x 100
Speed at Max pull (km/hr)	2
Max speed (km/hr)	5
Pull at Max speed (kN)	2 x 20

Hydraulic Transmission	
Closed hydraulic with pull pre-setting system that automatically adjust pulling speed.	

Characteristics	
Bull-wheel diameter (mm)	1500
Bull-wheel material	NYLON
Max conductor diameter (mm)	42
Max rope diameter (mm)	21
Weight (without rope) (kg)	7300
Number of grooves	12
Suitable for	2 conductors
Layout	Twin

Engine	
Diesel (kW)	105 (140hp)
Cooling System	Water
Electrical System	24V

Configuration	
<p>Tesmec digital HMI. Automatic reel winder. Lockable sound proof integrated covers. Rope clamp for reel change. Negative self-acting hydraulic brake. Rigid axle 30 km/h. Earthing connection point. Hydraulic front stabilizers. Power pack to control 2 reel stands or 2 reel-winders.</p> <p>Gearbox with 3 operating positions on 1 circuit:</p> <ul style="list-style-type: none"> <li>• Neutral position (with free bull-wheels for conductor loading and unloading).</li> <li>• Low tension position: <ul style="list-style-type: none"> <li>- 4 to 17kN as tensioner</li> <li>- 0 to 17kN as puller</li> </ul> </li> <li>• Nominal tension position.</li> </ul>	

Available Options	
ALL005	Hydraulic power for compressor
ALL037	Preheating device up to -30°C
ALL089	Electronic connection and synchronization between machines
ALL216	External printer
ALL270	Remote Diagnostic system with GPS localization including 3-year subscription
ALL280	Automatic grease pump.



7" COLOUR DISPLAY



RADIO REMOTE CONTROL

## 140kN/160kN Digital Puller Tensioners



Part No. PT2600

**140kN**  
MAX PULL/TEN



MAX TENSION

2 x 70kN



MAX SPEED

5km/h



CONDUCTOR DIAMETER

51 mm

Part No. PT2601

**160kN**  
MAX PULL/TEN



MAX TENSION

2 x 80kN



MAX SPEED

5km/h



CONDUCTOR DIAMETER

51 mm

- Tesmec Digital HMI  
178mm (7") Colour Display.  
Radio Remote Control  
Data Recorder
- Available for road use
- Integrated covers

Performance		
Max pull/tension (kN)	PT2600	2 x 70/ 1 x 140
	PT2601	2 x 80/ 1 x 160
Speed at Max pull/tension (km/hr)	PT2600	2
	PT2601	1.5
Max speed (km/hr)	PT2600	5
	PT2601	
Pull at Max speed (kN)	PT2600	2 x 25
	PT2601	2 x 45

Hydraulic Transmission	
Closed hydraulic with pull pre-setting system that automatically adjust pulling speed.	

Engine	
Diesel (kW)	129 (173hp)
Cooling System	Water
Electrical System	24V

Characteristics		
Bull-wheel diameter (mm)	1800	
Bull-wheel material	NYLON	
Max conductor diameter (mm)	51	
Max rope diameter (mm)	PT2600	25
	PT2601	28
Weight (without rope) (kg)	PT2600	11000
	PT2601	11750
Number of grooves	12	
Suitable for	2 ropes/ conductors	
Layout	Twin	

Available Options	
ALL005	Hydraulic power for compressor
ALL037	Preheating device up to -30°C.
ALL087	Low tension device
ALL089	Electronic connection and synchronization between machines.
ALL261	External printer
ALL270	Remote Diagnostic system with GPS localization including 3-year subscription.
ALL280	Automatic grease pump

Configuration	
Tescmec digital HMI.	
Automatic reel winder.	
Lockable sound proof integrated covers.	
Rope clamp for reel change.	
Negative self-acting hydraulic brake.	
Rigid axle 30 km/h.	
Earthing connection point.	
Hydraulic front stabilizers.	
Power pack to control 2 reel stands or 2 reel winders.	



7" COLOUR DISPLAY



RADIO REMOTE CONTROL



## Digital Tensioner - Helicopter stringing - TESMEC

### 30kN Hydraulic Tensioner

Part No. TN1216/CVR827



TN1216



CVR827



**PATENTS APPROVED**



**MAX TENSION**  
30kN



**MAX SPEED**  
25km/h



**CONDUCTOR DIAMETER**  
51mm

### Three Stages Of Safety

Machine has inbuilt safety features, a must when helicopter stringing. The machine can deal with the three safety scenarios

1. Hydraulic Failure
2. Engine Failure
3. Electronics Failure



The only Tesmec machine designed for HELICOPTER stringing, with a Stringing speed up to 25km per hour

Performance	
Max tension (kN)	30
Intermittent speed(km/hr)	25
Max speed at pullback (km/hr)	1
Max pull back (kN)	45

Hydraulic Transmission	
Hydraulic open circuit that provides very sensitive tensioning control and negligible deviations of tension in case of speed change.	

Characteristics	
Bull-wheel diameter (mm)	1800
Bull-wheel material	NYLON
Max conductor diameter (mm)	51
Weight of power unit (kg)	800
Weight of working unit (kg)	3200
Total with fluid (kg)	4600
Number of grooves	6
Suitable for	1 ropes
Layout	Single

- Tesmec Digital HMI
- 178mm (7") Colour Display.
- Radio Remote Control
- Data Recorder
- Detachable in two parts
- Designed to work joined with CVR827
- Integrated covers

Engine	
Diesel (kW)	48kw (65hp)
Emission level	tier4i/ Stage IIIA
Cooling System	Water
Electrical System	24V

Configuration	
Negative self-acting hydraulic brake.	
Control instruments for hydraulic system and Diesel engine.	
Rigid axle 30 km/h.	
Hydraulic power pack to control a reel stand with hydraulic motor.	
Earthing connection point.	
Radio control.	

CVR827 Performance	
Max Tension @ 2500mm External Reel Dia. (kN)	1.3
Max Tensioning Speed (km/h)	25
Max Recovering Speed (km/h)	1.5
Max Tension in emergency mode @ 1500mm average reel Dia. (kN)	5
Reel Dimension and Weight	
External diameter (mm)	From 600 - 2500
Width (mm)	From 570 - 2400
Total Weight (kg)	7500

Available Options	
ALL037	Preheating device for use up to -30°C.
ALL071	Hydraulic rope clamp for reel change operations



7" COLOUR DISPLAY



RADIO REMOTE CONTROL

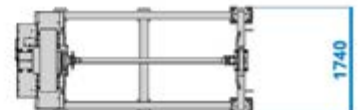

CVR827



3595



3875

## Continuous Line Pullers - TESMEC

### 50kN Continuous Line Puller Part No. CLP500

The new Continuous Line Puller (CLP500), gives an effective solution for handling and recycling old conductors during reconductoring with minimal interruption to the project. The CLP eliminates the need for placing old conductor on reels by effectively cutting the used conductor into small manageable pieces that are easy to transport and ready to recycle.



**MAX PULL**  
50kN



**MAX SPEED**  
3km/h



**ROPE DIAMETER**  
16mm

### Cutting Capacity



**M.S. JOINT DIAMETER**  
60mm



**CONDUCTOR DIAMETER**  
40mm



- Tesmec Digital HMI  
178mm (7") Colour Display  
Radio Remote Control  
Data Recorder
- Integrated covers

Performance	
Max pull (kN)	50
Speed at Max pull (km/hr)	1.5
Max speed (km/hr)	3
Pull at Max speed (kN)	30
Characteristics	
Conductor diameter (mm)	40
Max midspan joint diameter (mm)	60
Max rope diameter (mm)	16
Weight (without rope) (kg)	13000
Storage capacity (m)	350
Suitable for	ACSR conductor
Layout	Single

Engine	
Diesel (kW)	160 (215hp)
Cooling System	Water
Electrical System	24V
Cutting Module	
Max speed (km/hr)	3
Pull at Max speed (kN)	17kN
Suitable for	ACSR conductor
Max conductor diameter (mm)	40
Max midspan joint diameter (mm)	60
The module can be integrated with the magnetic sorting of aluminium and steel (ALL700/ALL750)	

Configuration	
Motorised Conveyors	
<ul style="list-style-type: none"> <li>• Hydraulic driven conveyor</li> <li>• Hydraulic conveyor deployment</li> </ul>	

Auxiliary Winch	
Max pulling force (kN)	50
Speed at max pull (km/hr)	2.5
Max rope diameter	16
Storage capacity (m)	350

Available Options	
ALL261	External printer
21035851	Trailer with stabiliser legs
ALL700	Motorised magnetic separation pulley embedded in the cutting module evacuation belt
ALL750	Additional motorised magnetic sorting belt

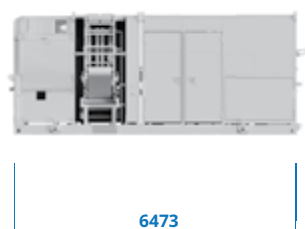
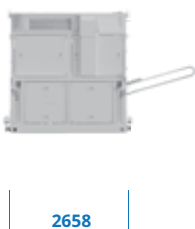

7" COLOUR DISPLAY



RADIO REMOTE CONTROL

### 50kN Continuous Line Puller

Part No. CLP501

The new Continuous Line Puller (CLP501), gives an effective solution for handling and recycling old conductors during reconductoring with minimal interruption to the project



**MAX PULL**  
50kN



**MAX SPEED**  
3km/h



**ROPE DIAMETER**  
16mm



- Tesmec Digital HMI  
178mm (7") Colour Display  
Radio Remote Control  
Data Recorder
- Integrated covers

Auxiliary Winch	
Max pulling force (kN)	50
Speed at max pull (km/hr)	2.5
Max rope diameter	16
Storage capacity (m)	350

Performance	
Max pull (kN)	50
Speed at Max pull (km/hr)	2.5
Max speed (km/hr)	3
Pull at Max speed (kN)	30

Hydraulic Transmission	
Closed hydraulic with pull pre-setting system that automatically adjust pulling speed.	

Characteristics	
Conductor diameter (mm)	25-40
Max midspan joint diameter (mm)	60
Max rope diameter (mm)	16
Weight (without rope) (kg)	7000
Storage capacity (m)	350
Suitable for	1 conductor
Layout	Single

Engine	
Diesel (kW)	81 (110hp)
Cooling System	Water
Electrical System	12V

Configuration	
Tescmec digital HMI.	
Integrated pull and speed recorder.	
Full electronic management.	
Manual and automatic use.	
Rigid axle 30 km/h.	
Hydraulic front stabilizers.	
Power pack to control 1 reel stand with hydraulic head or 1 reel winder.	
Lockable sound proof integrated covers.	

Available Options	
ALL037	Preheating device up to -30°C.
ALL073	Self anchoring system
ALL118	Hook loader system
ALL080	Special sector for GW/OPGW from 10mm to 25mm
ALL089	Electronic connection and synchronization between machines.
ALL261	External printer
ALL270	Remote Diagnostic system with GPS localization
ALL280	Automatic grease pump
ALL225	Auxiliary winch

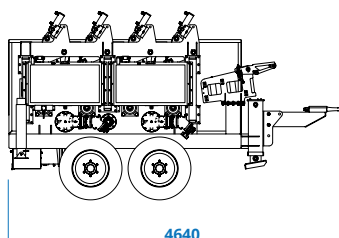
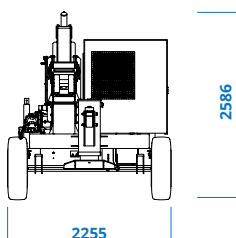

7" COLOUR DISPLAY



RADIO REMOTE CONTROL



## Equipment Winches - TESMEC

### 30kN Drum Winches

Part No. AMC402

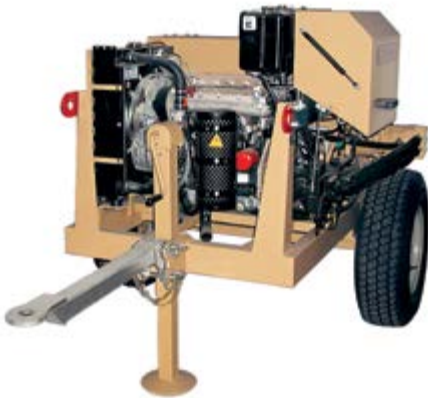

MAX PULL

30kN



MAX SPEED

5km/h



ROPE DIAMETER

14mm

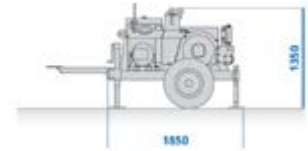

Ideal for lifting equipment and Transmission hardware

Drum Specifications		
Part No.	AMC402	AMC501
External OD (mm)	530	700
Internal OD (mm)	355	457
Width (mm)	700	700
Rope OD (mm)	14	18
Rope Capacity (m)	400	400
Weight (kg)	1000	1600

Engine (AMC402)	
Diesel (kW)	25 (34hp)
Cooling System	Water
Electrical System	12V

### 50kN Drum Winches

Part No. AMC501



MAX PULL

50kN



MAX SPEED

6km/h



ROPE DIAMETER

18mm

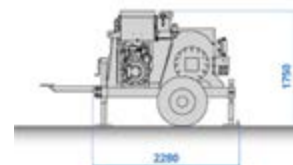

Performance*		
Part No.	AMC402	AMC501
Max pull (kN)	30	50
Speed at max pull (km/hr)	1.5	1.3
Max speed (km/hr)	5	6
Pull at max speed (kN)	8.5	10.5

Configuration	
	<ul style="list-style-type: none"> <li>• Drum with automatic level wind.</li> <li>• Negative self-acting hydraulic brake.</li> <li>• Hydraulic dynamometer with set-point and automatic control of maximum pull.</li> </ul>

Available Options AMC402/501	
ALL102	Pulling rope locking device when capstan is used (compulsory for Australian market)
ALL107	Capstan for lifting operations

Engine (AMC501)	
Diesel (kW)	34 (46hp)
Cooling System	Water
Electrical System	12V

### Hydraulic Pullers - TESMEC

#### 15kN Hydraulic Puller

**Part No. ARS200**

The ARS200 Hydraulic Puller is suitable to string one rope. The bull wheel grooves are made of heat treated steel.



MAX PULL

15kN



MAX SPEED

0.7km/h



ROPE DIAMETER

8mm

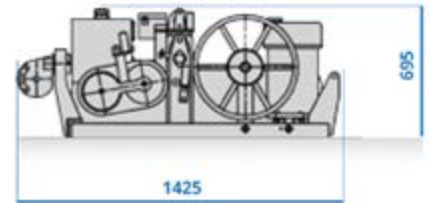

Performance	
Max pull (kN)	15
Speed at max pull (km/hr)	0.7
Max speed (km/hr)	3.6
Pull at max speed (kN)	4
Hydraulic Transmission	
Closed hydraulic circuit for stepless speed variation in both rotating directions	

Configuration
<ul style="list-style-type: none"> <li>Negative self-acting hydraulic brake</li> <li>Hydraulic dynamometer with set-point and automatic control of maximum pull</li> <li>On board reel winder with automatic level wind and special reel BOF370 for 500m of 8mm rope</li> </ul>

Characteristics	
Bull Wheel dia (mm)	200
Max rope dia (mm)	8.0
Weight (without rope) (kg)	500
Engine	
Petrol (kW)	13 (18hp)
Cooling System	Air
Electrical System (V)	12

#### 30kN Hydraulic Puller

**Part No. PL1150**

The PL1150 Hydraulic Puller is suitable to string one rope. The bull wheel grooves are made of wear proof thermally treated steel.



MAX PULL

35kN



MAX SPEED

3.6km/h



ROPE DIAMETER

13mm

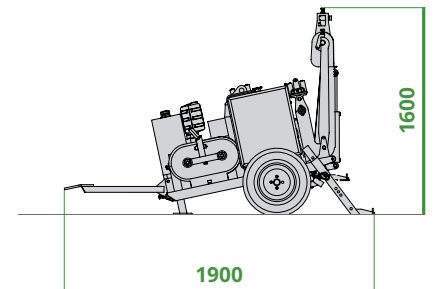

Performance	
Max pull (kN)	30
Speed at max. pull (km/hr)	1
Max speed (km/hr)	3.2
Pull at max. speed (kN)	10
Hydraulic Transmission	
Closed hydraulic with pull pre-setting system that automatically adjust pulling speed.	

Configuration
<ul style="list-style-type: none"> <li>New Digital HMI 127mm (5") display</li> <li>Negative self-acting hydraulic brake</li> <li>On board automatic reel winder</li> <li>Pull recorder &amp; Digital meter counter</li> </ul>

Characteristics	
Bull Wheel dia. (mm)	350
Max. rope dia. (mm)	13
Mass (without rope) (kg)	980
Engine	
Diesel (kW)	19 (26hp)
Cooling System	Water
Electrical System (V)	12

### TESMEC



Performance	
Max pull (kN)	35
Speed at max pull (km/hr)	1.2
Max speed (km/hr)	3.6
Pull at max speed (kN)	12
Hydraulic Transmission	
Closed hydraulic circuit for stepless speed variation in both rotating directions	

**Ideal for Overhead & Underground Projects**

## 35kN Hydraulic Puller

### Part No. ARS403

The ARS403 Hydraulic Puller is suitable to string one rope. The bull wheel grooves are made of wear proof thermally treated steel.

Characteristics	
Bull Wheel dia (mm)	325
Max rope dia (mm)	13
Weight (without rope) (kg)	980
Engine	
Diesel (kW)	25 (34hp)
Cooling System	Water
Electrical System (V)	12

Configuration	
<ul style="list-style-type: none"> <li>Negative self-acting hydraulic brake</li> <li>Hydraulic dynamometer with set-point and automatic control of maximum pull</li> <li>On board reel winder with automatic level wind suitable for standard reel BOF010 and BOF020 (AXR001 included)</li> </ul>	



**MAX PULL**  
35kN



**MAX SPEED**  
3.6km/h



**ROPE DIAMETER**  
13mm



Trailer mounting and Mine spec. options available. Contact TEN for further information

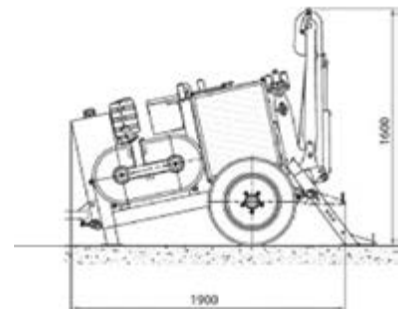

## 240 kN Hydraulic Puller

### Part No. ARS802

The ARS802 Hydraulic Puller is suitable to string one rope. The bull wheel grooves are made of wear proof thermally treated steel. The machine is completely electronically controlled

Configuration	
<ul style="list-style-type: none"> <li>Negative self-acting hydraulic brake</li> <li>Hydraulic dynamometer with set-point and automatic control of maximum pull</li> <li>On board reel winder with automatic level wind suitable for standard reel BOF020 and BOF030 (AXR002 included)</li> </ul>	



**MAX PULL**  
240kN



**MAX SPEED**  
4.5km/h



**ROPE DIAMETER**  
32mm



Performance	
Max pull (kN)	240
Speed at max pull (km/hr)	2.5
Max speed (km/hr)	4.5
Pull at max speed (kN)	130
Hydraulic Transmission	
Closed hydraulic circuit for stepless speed variation in both rotating directions	

Characteristics	
Bull-wheel diameter (mm)	800
Max rope dia (mm)	32
Weight (kg)	10000
Suitable for	1 rope
Layout	Single
Diesel	280kW

Engine	
Diesel (kW)	280 (375hp)
Cooling System	Water
Electrical System (V)	24





## Reel Winders, Drum Elevators and Stands - TESMEC

### Reel Winders

#### Part No. RVA001

- Operates on any Tesmec machine with hydraulic outlets
- Compact design and easy to handle
- Automatic level wind.
- Negative self-acting hydraulic brake
- Hydraulic jacks powered by the same hydraulic source.
- Rigid semiaxles for manual towing

Suits standard reels mod.  
BOF010, BOF020, BOC040 and BOC050.  
Extra shaft AXR001 is included.

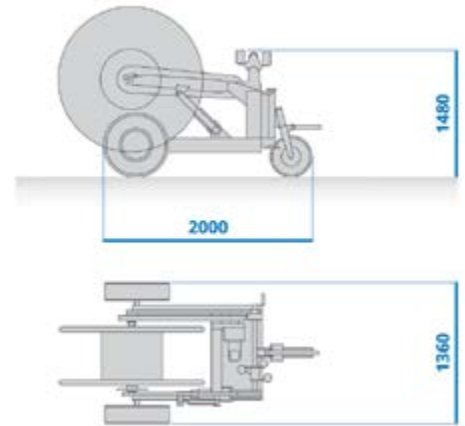

Performance	
Capacity (kN)	20
Torque (kNm)	1
Rotating speed (rpm)	50
Weight (kg)	525

Kit of Connecting Hoses	
TUT001	Length 7m
TUT002	Length 10m
TUT003	Length 15m

### Cradle Reel Elevators

#### Part No. CVC002

- Detachable frame
- Light design



Available Options	
CDF007	Disk brake device for model CVC002 (Max torque 1.3kN-m).

Part No.	Dimensions (mm)			Reel Part No.	Capacity (kN)	Wt (kg)
	A	B	C			
CVC002	2200	900	910	BOF010	20	58
				BOF020		

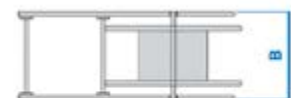
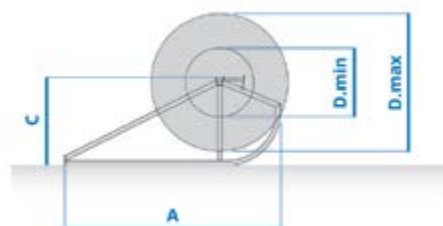

## Hydraulic Drum Elevators - Heavy Duty

### CVI Series

- Operates on any Tesmec machine with hydraulic outlets
- Compact design and easy to handle



Drum Elevator (CVI609) shown with axle for steel drum (CDT063)

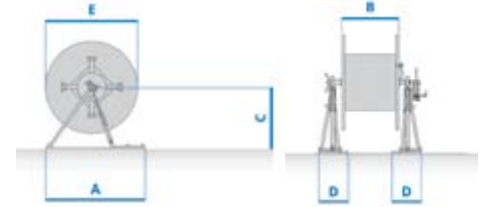

Part No.	Dimensions (mm)								Capacity (kN)	Wt (kg)
	A	B min	B max	C min	C max	D	E min	E max		
CVI609	2140	800	1500	580	1340	640	1200	2500	80	285
CVI600	2140	800	1500	580	1340	640	1200	2500	80	305
CVI810	2500	800	1850	720	1725	740	1500	3200	100	550

Configuration for CVI609	Configuration for CVI600	Configuration for CVI810
*No Brake	One manual disk brake CDF012 (max torque 1.0kN-m)	One manual disk brake CDF059 (max torque 2.3kN-m)

Typical Available Options for CVI609		Typical Available Options for CVI600		Typical Available Options for CVI810	
<b>CDT063</b>	Supports with self-locking fixing wedges for wooden conductor drums. Max reel hole diameter = 125 mm.	<b>CDT063</b>	Supports with self-locking fixing wedges for wooden conductor drums. Max reel hole diameter = 125 mm.	<b>CDT***</b>	Supports with self-locking fixing wedges for wooden conductor drums.
<b>TIH001</b>	Fast assembling hydraulic motor for control of the drum winding and unwinding.	<b>TIH001</b>	Fast assembling hydraulic motor for control of the drum winding and unwinding.	<b>TIH007</b>	Fast assembling hydraulic motor for control of the drum winding and unwinding.
<b>TUT002</b>	Kit of connecting hoses. Length 10m, weight 15 Kg.	<b>TUT002</b>	Kit of connecting hoses. Length 10m, weight 15 Kg.	<b>TUT002</b>	Kit of connecting hoses. Length 10m, weight 15 Kg.

## Drum Stand

### Part No. CVR624

- Ready to use
- Suitable for different reel dimensions
- One manual disk brake CDF012 (Max torque 1kN-m)
- Refer page J23 for hydraulic Hoses (TUT002)



Typical Available Options for CVR624	
<b>CDR124</b>	Support with fixed wedges for wooden conductor drums.
<b>CDT123</b>	Special driver with fixed wedges for steel reels conductor.
<b>CDA125</b>	Adapter for steel rope standard reels.
<b>TIH001</b>	Easily assembled hydraulic motor for drum winding

Part No.	Dimensions (mm)						Capacity (kN)	Wt (kg)
	A	B max	B min	C	D	E		
<b>CVR624</b>	2750	1700	1400	1580	2170	2840	70	365

## Heavy Duty Drum Stand

### Part No. CVR824

Integrated hydraulic motor. Hydraulic transmission powered by existing machines. Universal drive shaft. Incorporated disk brake for emergency breaking in case of absence of hydraulic power. (Max Torque 2.3kN-m) Simple drive transmission engagement by means of slide shaft. Rollers supported shaft.



Part No.	Dimensions (mm)						Capacity (kN)	Wt (kg)
	A	B max	B min	C	D	E		
<b>CVR824</b>	2000	1650	-	1618	3057	3000	120	930

Other sizes & lengths available  
- Contact TEN for further  
information



## Standard Reel Adaptor

### Part No. CDA078/079

- Adaptor for steel rope standard reel (BOF330, BOC 310, BOC320)



### Part No. CDA060

- Adaptor for steel rope standard reel (BOF010-BOF020-BOF030-BOC040-BOC050) (only for CVI810)

### Part No. CDA004

- Adaptor for steel rope standard reel (BOF010-BOF020-BOF030-BOC040-BOC050) (only for CVI600)

## Drum Supports

### Part No. CDT063

- Reel hole diameter 82 to 125mm (only for CVI600)
- Special driver with fixed wedges for steel conductor reels

Part No.	Reel Width (mm)		Guide arm Hole Dia (mm)	Spindle Dia (mm)
CDT063	1500 min	1650 max	33	80

(Reel drawing is required)



## Hydraulic Hose Set

### Part No. TUT Series

Part No.	Length (m)	Wt (kg)
TUT001	7	11
TUT002	10	15
TUT003	15	23



## Hydraulic Motor - Reel Winder

### Part No. TIH Series

Fast assembling hydraulic motor for control of the drum winding and unwinding.

Part No.	Max Torque (kNm)	Max Rotation (rpm)	Wt (kg)
TIH001	1.8	45	76
TIH002	1.8	45	78
TIH006	2.3	32	78
TIH007	2.3	37	78
TIH010	5	30	120
TIH013	2.4	35	500

## Auto Rope Leveler

### Part No. CDD005

Special automatic level wind for steel conductor reels on demand.

- Automatic level wind for standard steel rope reels (BOF010-BOF020-BOC040-BOC050) (only for CVI600)

## Hydraulic Pressure Relief Kit

### Part No. TUK054

Kit to remove residual hydraulic pressure on hoses.





## Reels - TESMEC

### Standard Fixed Reels

#### BOF Series



BOF

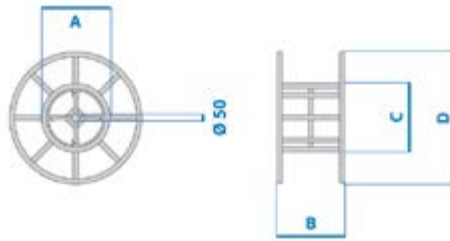

- World wide standard design
- Welded steel with protective coating

### Cross Support

#### BOS360



BOS360

- Two cross arms included
- Weight with bolts: 2.6 Kg



Part No.	Dimensions (mm)				Wt (kg)
	A	B	C	D	
BOF010	420	560	570	1100	53
BOF020	420	560	570	1400	73
BOF030	420	560	570	1900	135
BOF330	420	1560	1010	2200	1200

ROPE (mm)	Reel Max Capacity for anti-twisting braided rope (m)			
	Part No.			
	BOF010	BOF020	BOF030	BOF330
6	6300	10000	22200	76000
8	3900	7100	13700	47000
9	3200	5900	11500	39200
11	2300	4300	8400	28800
13	1600	2850	5600	19400
15	1150	2000	4100	14550
16	1030	1900	3700	12400
18	800	1400	2800	9750
19	780	1400	2800	9300
21	-	1050	2150	7100
22	-	950	1900	6400
23	-	860	1750	6000
25	-	750	1550	5100
26	-	700	1400	4700
28	-	600	1150	4000
31	-	430	850	3100

### Detachable Reels

#### Part No. BOC Series

- World wide standard design
- Welded steel with protective coating

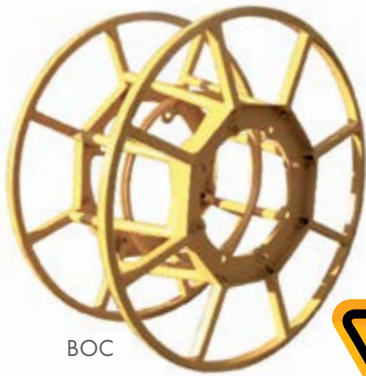

BOC



BOC040, BOC050  
& BOC310 ONLY



Cross Support  
BOS360

Part No.	Dimensions (mm)				Wt (kg)
	A	B	C	D	
BOC040	420	560	590	1100	75
BOC050	420	560	590	1400	86
BOC310	420	890	626	1900	210
BOF320	420	1310	605	2050	250

ROPE (mm)	Reel Max Capacity for anti-twisting Steel braided rope (m)			
	Part No.			
	BOC040	BOC050	BOC310	BOC320
6	5600	10900	36000	63000
8	3500	6700	22200	38500
9	2850	5580	18200	32600
11	2150	4100	13300	23800
13	1400	2750	9000	16100
15	1100	2050	6800	11700
16	950	1750	6000	10600
18	700	1350	4500	7800
19	700	1300	4300	7800
21	-	1000	3400	6000
22	-	850	3000	5200
23	-	800	2800	4800
25	-	750	2400	4200
26	-	650	2100	3900
28	-	550	1900	3300
31	-	420	1450	2500

### Ropes

#### Anti Twisting Steel Braided Rope Standard - TESMEC

#### Part No. FUA Series



- High flexibility
- Complete stability to rotation
- Strands with individual galvanized elementary wires

Part No.	Working Load (kN) *	Nominal Dia (mm)	Indicative Lubricated Linear Wt (kg/m)	Minimum Breaking Load (kN) *	Standard length (m) **
FUA006	7.6	6	0.114	22.9	1800-3600
FUA008	14.2	8	0.22	42.6	1600
FUA611	25	11	0.359	75	1100
FUA613	35	13	0.502	105	800-1600
FUA615	50	15	0.712	150	900-1800
FUA618	75	18	1.072	225	1200
FUA621	100	21	1.429	300	900
FUA623	120	23	1.718	360	800
FUA625	140	25	2.004	420	700
FUA628	180	28	2.572	540	600

\* This value is related to rope with spliced eyes and for stringing operation

\*\* The rope is also available in different lengths and in continuous sections up to 7000m

### Double Braided Hauling Rope - Hampidjan

Part No. Various



- Manufactured in Australia with a braided polyester cover over a braided Polyester core
- Ideal for use as winch and tow lines and for pulling cable

#### Characteristics

- High strength
- High UV resistance
- Splicable
- Flexible

#### Applications

- Winch lines
- Tow lines
- Rigging lines
- Pulling and stringing line

Part No.	OD (mm)	Wt per 100m (kg)	Max Break Force (T)
DBPR-12	12	11.10	3.49
DBPR-14	14	13.90	4.36
DBPR-16	16	18.25	5.75
DBPR-18	18	22.20	6.98
DBPR-20	20	27.30	8.59
DBPR-22	22	33.30	10.48
DBPR-24	24	41.60	13.10
DBPR-26	26	46.30	14.56

Specify the length requested in metres

### Robus Dyneema Rope - Hampidjan

Part No. Various



ROBUS rope is an ultra-high strength, low cost solution that meets the need for light but strong ropes in cost driven environment. Prima rope is stronger than steel in the same diameter. ROBUS ropes are made from HMPE fibre produced by DSM Dyneema.

#### Characteristics

- Extremely high strength
- Lightweight
- Abrasion resistant
- Low stretch
- Neutral buoyancy
- Splicable
- Flexible

#### Applications

- Alternate to wire rope
- Winch lines
- Tow lines
- Rigging lines
- Utility line

Part No.	OD (mm)	Wt per metre (g)	Max Break Force (T)
29081035	6	23.29	4.0
29081040	8	38.81	6.7
29081050	10	54.34	10.7
29081061	12	93.15	16.0
29081070	14	103.25	18.7
29081080	16	137.67	24.9

Specify the length requested in metres



1000m AVAILABLE OF H-53-010-1000 ONLY

More sizes available Contact TEN

Available with Polyester Jacket on Request

### Polypropylene Rope 3 Strand - Hampidjan

Part No. Various



- Higher breaking strength
- Abrasion resistance
- Excellent shock absorption
- Better grip
- Minimal elongation
- Durable and ultraviolet stabilized
- Excellent shape retention
- Strength: wet/dry 100%
- Floats/sinks: Floats
- Elongation: Moderate
- Water absorption: None
- Chemical Resistance
  - Acids: Excellent
  - Alkalis: Excellent
  - Oil/Gas: Very Good

Part No.	OD (mm)	Wt per 100m (kg) 250m Standard (Coil)	Max Break Force (T)
PPR-12	12	7.0	2.84
PPR-14	14	9.0	3.91
PPR-16	16	12.0	4.90
PPR-18	18	15.0	5.50
PPR-20	20	18.0	7.52
PPR-22	22	22.0	8.45
PPR-24	24	26.0	10.20
PPR-26	26	31.0	11.87

Specify the length requested in metres



### Fixed Joints, Swivels, Grips and Socks

#### Fixed Joint - TESMEC

Part No. GFT Series



- Highly tensile forged galvanised steel
- Compact shape for bull wheel grooves

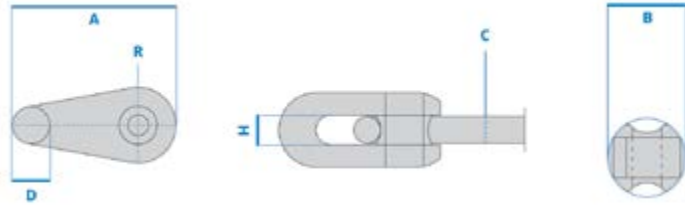

Part No.	Dimensions (mm)						Working Load (kN)	Wt (kg)
	A	B	C max	D	H	R		
GFT001	59	28	10	15	11	11	23	0.3
GFT010	74	40	13	19.5	14	15	37	0.33
GFT020	91	48	16	20	19	18	53	0.53
GFT030	102	54	18	22	19	20	73	0.75
GFT040	121	60	24	27	26	22	120	1.03
GFT050	174	75	28	42	30	32	250	3.03
GFT060	183	81	32	42	34	34.5	250	3.4

#### Swivel Joint - TESMEC

Part No. GGT Series

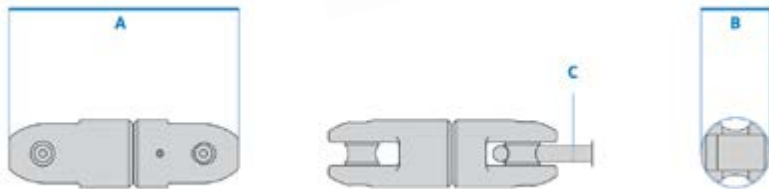

Part No.	Dimensions (mm)			Working Load (kN)	Wt (kg)
	A	B	C max		
GGT001	106	28	10	23	0.3
GGT010	143	40	13	37	0.93
GGT020	184	54	18	73	2.15
GGT030	234	60	24	120	3.4
GGT040	322	77	28	250	8.2
GGT180	336	81	32	250	8.7
GGT260	403	104	38	330	19.5

### TESMEC

## Heavy Duty Large Eye Conductor Socks - TESMEC

### Part No. GCT Series

- Ideal for Transmission overhead work
- Suitable for Transmission & Distribution AL, CU & ST
- Colour coded plastic bands at ferrule to identify range and capacity
- Steel wires with protective finish and alloy ferrule
- Long mesh length provides additional gripping surface area
- Protective shoulders - protects the sock from sharp edges on the conductor during stringing
- Flexible & Reusable



Part No.	Suitable Swivel	Conductor OD Ø (mm)	Colour	UTS (kN)	Mesh Length (mm)	Wt (kg)
GCT001	GGT001	8 - 17	Yellow	35	1100	0.7
GCT010	GGT010	17 - 29	Red	85	1360	1.3
GCT020	GGT020	29 - 38	Green	130	1470	2.1
GCT030	GGT020, GGT030	38 - 50	Black	180	1820	2.7

## Heavy Duty Conductor Double Head Sock - TESMEC

### Part No. GCT



Scan or Click to View or Download Grip Inspection Selection & Application

Part No.	Conductor OD Ø (mm)	Colour	UTS (kN)	OAL (mm)	Wt (kg)
GCT500	8 - 17	Yellow	35	2680	1.15
GCT510	17 - 29	Red	85	3240	2.3
GCT520	29 - 38	Green	130	3540	3.6
GCT530	38 - 50	Black	180	4240	4.8

## Radial Locking Clamps - TESMEC

### Part No. MOS



- Designed for long period anchorage
- Safe, with no damage to conductors

The radial locking clamp can be used whenever a conductor or a rope made of aluminium, aluminium/steel, copper or steel has to be stretched.

The body is made of high-strength steel. It is made up of a series of hinged elements, which can be locked by nuts. The interchangeable jaws are made of aluminium.

A special hook is provided at one end. The galvanisation treatment on the surface protects from oxidation.

Number of Eyebolts	Standard Diameter Range (mm)						C	E	F	WLL Max (kN)	Wt Min (kg)	Wt Max (kg)			
	20-30		30-40		40-56										
	Dimensions (mm)														
Part No.	A	B	A	B	A	B									
4	MOS700	158	143	MOS701	169	143	MOS702	178	158	605	75	26	40	18	19
6	MOS710	158	143	MOS711	169	143	MOS712	178	158	735	93	26	60	25	28
8	MOS720	158	143	MOS721	169	143	MOS722	178	158	852	93	26	80	30	33
10	MOS730	158	143	MOS731	169	143	MOS732	178	158	995	93	32	100	39	41
12	MOS740	158	143	MOS741	169	143	MOS742	178	158	1100	93	32	120	41	43
14	MOS750	158	143	MOS751	169	143	MOS752	178	158	1210	93	35	140	43	47
15	MOS753	158	143	MOS754	169	143	MOS755	178	158	1285	93	35	150	55	61
16	MOS760	158	143	MOS761	169	143	MOS762	178	158	1360	93	45	160	67	75
18	MOS770	158	143	MOS771	169	143	MOS772	178	158	1510	93	45	180	79	89
20	MOS780	158	143	MOS781	169	143	MOS782	178	158	1670	93	45	200	92	104

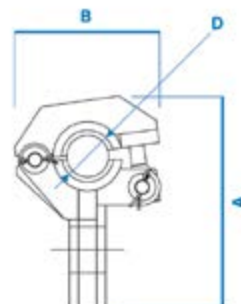
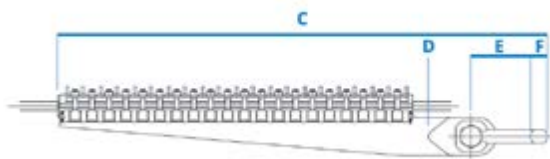

D = conductor diameter to be specified

Different jaws out of the standard diameter range are available upon request



### RIGANTI

### Grips - Riganti

#### Part No. Various

Riganti's self-gripping comealongs are available for aluminium, ACSR, steel earth-wire, anti-twisting rope, copper and OPGW conductors.

Made of high tensile alloy steel, hot forged, heat-treated, precision machined and zinc-plated with a complete range of interchangeable liners. This means working at lower costs on conductors of different materials and diameters only by changing the liners.

The liners are available in aluminium for aluminium or aluminium/steel conductors and bronze for copper conductors, steel anti-twisting rope and steel earth-wire.

For OPGW conductor the lower liner is made of Adiprene, whereas the upper liner is made of aluminium.

All Riganti self-gripping clamps comply with European safety standard CE. Special clamps with exact diameters available on request with or without liners.



Part No	Working Load Limit (kN)	Min Breaking Load (kN)	Interchangeable Liners	Al, ACSR & Cu		Steel, Earth wire		Anti-twist Steel Rope		Wt (kg)
				Min	Max	Min	Max	Min	Max	
				(mm)		(mm)		(mm)		
IR-3109	19.6	49	×	2.5	15	2.5	15	2.5	15	1.5
IR-3111 *	21.2	64	✓	7	16	7	13	7	13	2.5
IR-3108 *	39.5	110	✓	Lifting suspension conductors 7 - 38mm						5.5
IR-3106	50	125	×	7.5	18	7.5	18	7.5	18	7
IR-3107 *	49	180	✓	6	23	6	16	6	16	7
IR-3112 *	49	180	✓	OPGW 6 - 23mm						7
IR-3105-S *	88	275	✓	8	35.2	8	22	8	24	13.5
IR-3104-S *	117	310	✓	10	45	10	34	8	28	17

\* Exact size required for manufacture of liners

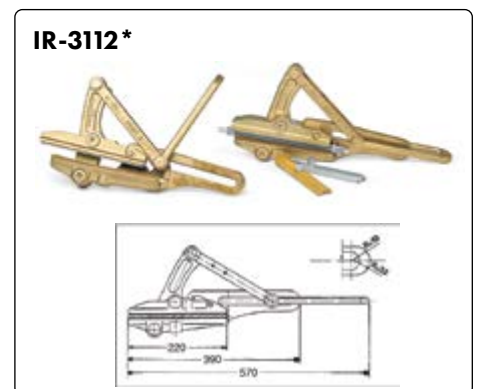
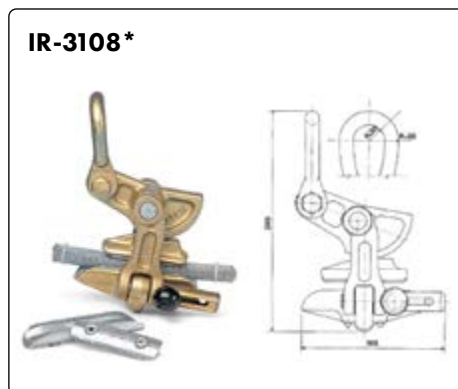
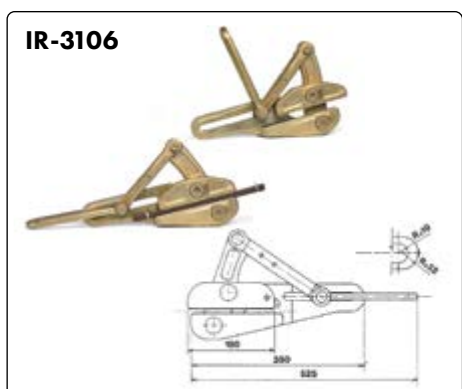
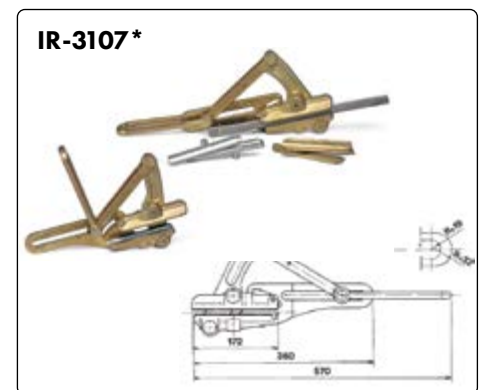
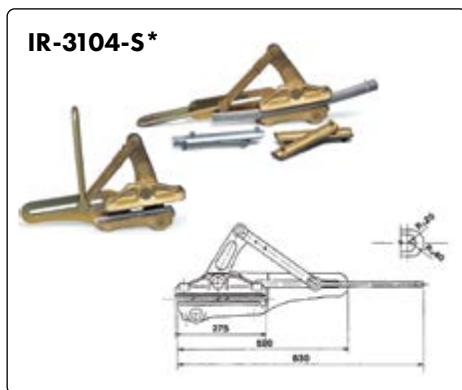

### RIGANTI



IR-3112 Liners



IR-3105 Liners

#### Liners for IR3104-S

Min (mm)	Max (mm)	Al Part No.	Cu Part No.
10.0	10.5	G4A100F	G4B100F
10.5	12.0	G4A105F	G4B105F
12.0	13.5	G4A120F	G4B120F
13.5	15	G4A135F	G4B135F
15.0	16.5	G4A150F	G4B150F
16.5	18	G4A165F	G4B165F
18.0	19.5	G4A180F	G4B180F
19.5	21.0	G4A195F	G4B195F
21.0	22.5	G4A210F	G4B210F
22.5	24.0	G4A225F	G4B225F
24.0	25.5	G4A240F	G4B240F
25.5	27.0	G4A255F	G4B255F
27.0	28.5	G4A270F	G4B270F
28.5	30	G4A285F	G4B285F
30.0	31.5	G4A300F	G4B300F
31.5	33.0	G4A315F	G4B315F
33.0	34.5	G4A330F	G4B330F
34.5	36.0	G4A345F	G4B345F
36.0	37.5	G4A360F	G4B360F
37.5	39.0	G4A375F	G4B375F
39.0	40.5	G4A390F	G4B390F
40.5	45.0	Specify Diameter	

AL & CU Liners check range above.

Liners for wires below require exact diameter:  
For steel & earth wires 10.0 - 34.0mm  
For anti-twist steel rope 8.0 - 28.0mm

#### Liners for OPGW IR3112

Lower liner made of Adiprene and upper liner made of Aluminium.

\*Specify exact OPGW diameter between **6.0 - 23.0mm**

Part No. **IR3112L\*\*.\*OP**  
e.g. **IR3112L11.3OP**

NOTE: IR3112 with 15.8mm AL to AL Liners (IR311215.8AL) is suitable for CCSX62 Amokabel

#### Liners - Riganti

#### Liners for IR3105-S

Min (mm)	Max (mm)	Al Part No.	Cu Part No.
8.0	9.0	G5A080F	G5B080F
9.0	10.5	G5A090F	G5B105F
10.5	12.0	G5A105F	G5B105F
12.0	13.5	G5A120F	G5B120F
13.5	15.0	G5A135F	G5B135F
15.0	16.5	G5A150F	G5B150F
16.5	18.0	G5A165F	G5B165F
18.0	19.5	G5A180F	G5B180F
19.5	21.0	G5A195F	G5B195F
21.0	22.5	G5A210F	G5B210F
22.5	24.0	G5A225F	G5B225F
24.0	25.5	G5A240F	G5B240F
25.5	27.0	G5A255F	G5B255F
27.0	28.5	G5A270F	G5B270F
28.5	30.0	G5A285F	G5B285F
30.0	31.5	G5A300F	G5B300F
31.5	35.2	Specify Diameter	

AL & CU Liners check range above.

Liners for wires below require exact diameter:  
For steel & earth wires 8.0 - 22.0mm  
For anti-twist steel rope 8.0 - 24.0mm

#### Liners for IR3107

Min (mm)	Max (mm)	Al Part No.	Cu Part No.
6.0		G7A060F	G7B060F
6.5	8.0	G7A065F	G7B065F
8.0	9.5	G7A080F	G7B080F
9.5	11.0	G7A095F	G7B095F
11.0	12.5	G7A110F	G7B110F
12.5	14.0	G7A125F	G7B125F
14.0	15.5	G7A140F	G7B140F
15.5	17.0	G7A155F	G7B155F
17.0	18.5	G7A170F	G7B170F
18.5	20.0	G7A185F	G7B185F
20.0	21.5	G7A200F	G7B200F
21.5	23.0	G7A215F	G7B215F

AL & CU Liners check range above.

Liners for wires below require exact diameter:  
For steel & earth wires 6.0 - 16.0mm  
For anti-twist steel rope 6.0 - 16.0mm

#### Liners for IR3111

Min (mm)	Max (mm)	Al Part No.	Cu Part No.
7.0	8.5	G1A070F	G1B070F
8.5	10.0	G1A085F	G1B085F
10.0	11.5	G1A110F	G1B110F
11.5	13.0	G1A115F	G1B111F
13.0	14.5	G1A130F	G1B130F
14.5	16.0	G1A145F	G1B145F

Liners supplied on request with exact diameter:

For round steel wires 7.0 - 13.0mm

For square steel wires 7.0 - 13.0mm

#### Liners for IR3108

Min (mm)	Max (mm)	Al Part No.
7.0	11.0	G8A070F
9.0	12.0	G8A090F
12.0	16.0	G8A120F
15.0	23.0	G8A150F
22.0	36.0	G8A220F
30.0	38.0	G8A300F

## OPGW Installation - TESMEC

### Optical Earth Wire Anti-Torque Devices

#### Part No. RFF Series

- Shaped for smooth operations
- Swivel included

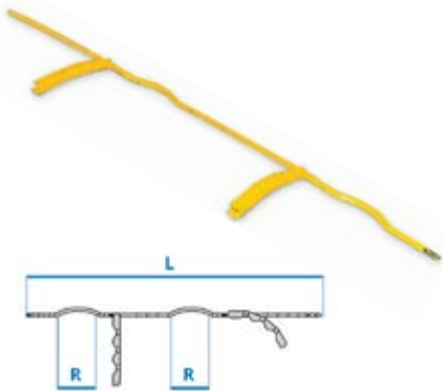

Part No.	Dimensions (mm)		Working Load (kN)	Wt (kg)	For Pulleys (mm)
	L	R			
RFF001	3900	350	10	60	400
					500
					650
RFF010	4300	500	10	63	800
					1000

### Pulling Clamp For Fibre Optic

#### Part No. MOF470

- Rigid design avoids fibre damage
- Interchangeable and machined jaws

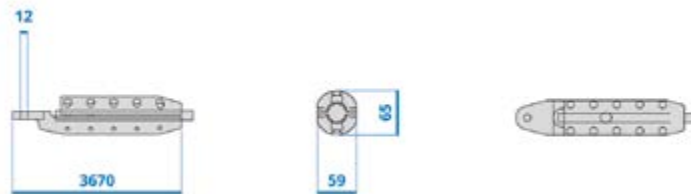

Performance	
Working load (kN)	10

Characteristics	
Diameter range	6 to 23
Weight (kg)	4
Material	Hot forged steel

Configuration
Aluminium interchangeable jaws part number GTRXXX: conductor diameter to be specified on order.

### Counterweight Device for stringing OPGW Cables

#### Part No. CO60 Series

- Non Rotating
- Supplied with interchangeable Liners

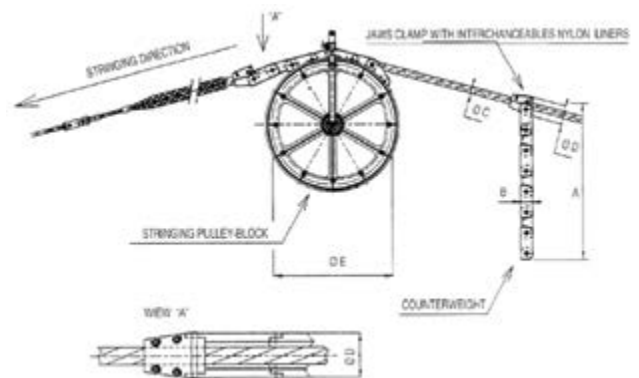

Part No.	Dimensions (mm)				Cable C (mm)	Quantity (* ) per set
	D OD (mm)	A (mm)	B (mm)	Wt (kg)		
CO60-9	60	990	30	8	10 - 17	2
CO60-12	60	1320	30	10.5	17- 23	2

\* Supplied with interchangeable liners - Nominate OPGW OD





**Ideal for Standard Conductor**

### Traction Machine

**Part No. TMT020**

The traction machine is ideal for reconducting both conductor and OPGW over road, rail, energised infrastructure & mountainous terrain as this method provides lower risk and better access.

- Highest traction force available
- Can be pulled back if machine stops
- Up to 1000m range with 2 remotes
- Vulcanised wheels
- Each motor supplied with 24V Lithium-Ion battery
- Lightweight

#### Remote Control

Two compact radio remote control units with double push-button transmission. Device operative range up to 1000 (m).

#### Available Options

**ALL304** Extra battery

Performance	
Max traction speed (m/min)	10
Max traction force (kg)	110
Max slope (°)	20

Characteristics	
Weight (kg)	55
Robot weight (kg)	40
Battery weight (kg)	15
Two electrical motors	24V
Conductors diameter range (mm)	10 to 46 mm
Material	Aluminium alloy
It can cross mid-span joint up to CH=60	



Rear View

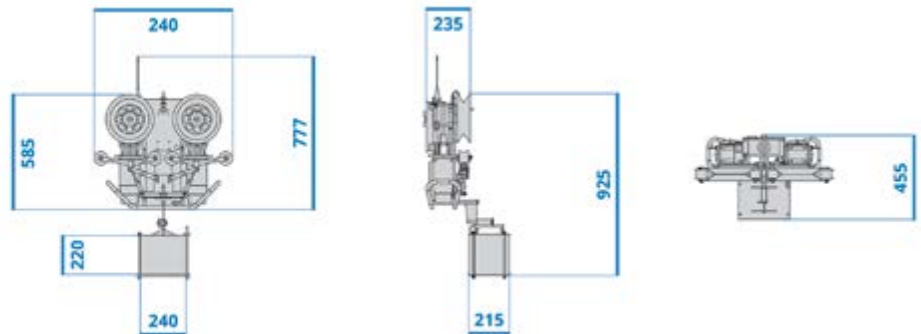

Remote Control

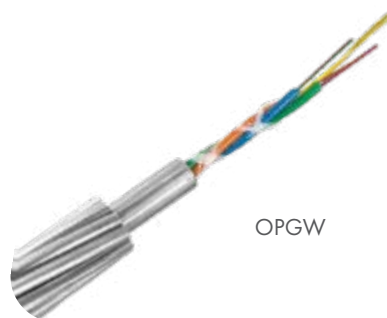

OPGW

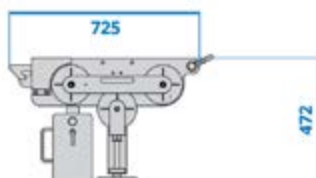

### Recovery Device

**Part No. TMR030**

- Automatic locking system
- Drag the traction machine to finish the span

Characteristics	
Max weight (kg)	40
Wheel material	Nylon
Detachable ballasts for easy lifting	

### Braking Device

Part No. ABR058

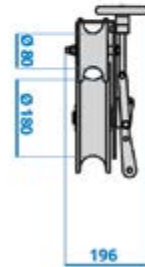
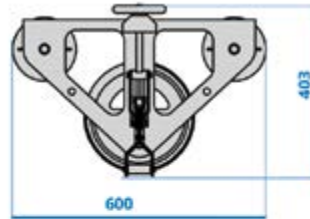

- Light and compact
- Allows the final recovery of the cradle Blocks

Performance	
Working load (kN)	1.5
Characteristics	
Weight (kg)	4.5
Conductor dia. range (mm)	10-30
Wheels material	Nylon
Frame material	Aluminium



### OPGW Cradle Blocks

Part No. ABR053

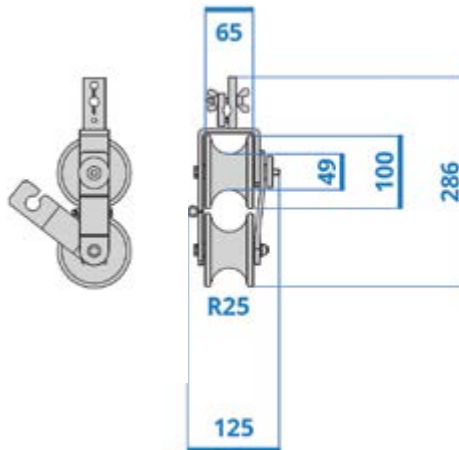

- Light and easy
- Adjustable for different diameters

Performance	
Working load (kN)	1
Characteristics	
Weight (kg)	1.4
Rollers material	Nylon
Frame material	Aluminium



Part No. ABR045

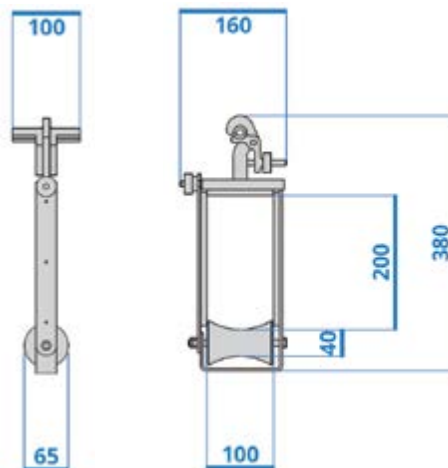

- Suitable also on midspan joints
- Allows the final recovery of the cradles

Performance	
Working load (kN)	2
Characteristics	
Weight (kg)	2
Rollers material	Nylon
Frame material	Galvanized steel
Internal surface covered by nylon plates	

### OPGW Cradle Blocks

Part No. ABR064

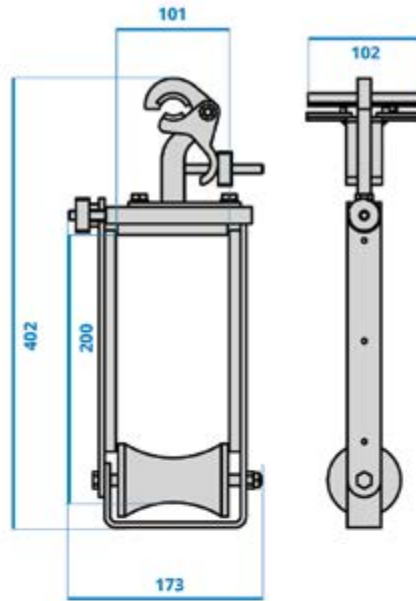

- Suitable also on midspan joints
- Adjustable for different diameters

Performance	
Working load (kN)	2
Characteristics	
Weight (kg)	1.9
Rollers material	Nylon
Frame material	Aluminium - connection made of steel
Internal surface covered by nylon plates	

Part No. ABR059

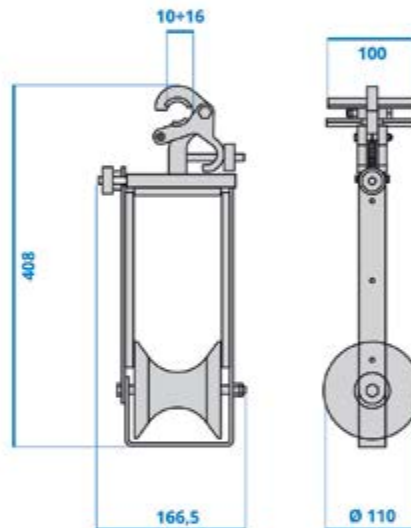

- Counterweight for easy rotation
- Quick open/close system

Performance	
Working load (kN)	2
Characteristics	
Weight (kg)	2
Rollers material	Nylon
Frame material	Galvanized steel
Internal surface covered by nylon plates	

Part No. ABR021

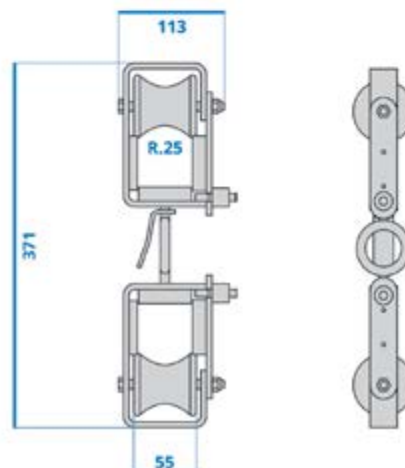

- Earth wire Earthed during the operations
- Quick locking system for guide rope

Performance	
Working load (kN)	2
Characteristics	
Weight (kg)	1.8
Rollers material	Nylon
Frame material	Galvanized steel
Internal surface covered by nylon plates	



## Stringing Rollers/Blocks and Pivoting Array Blocks

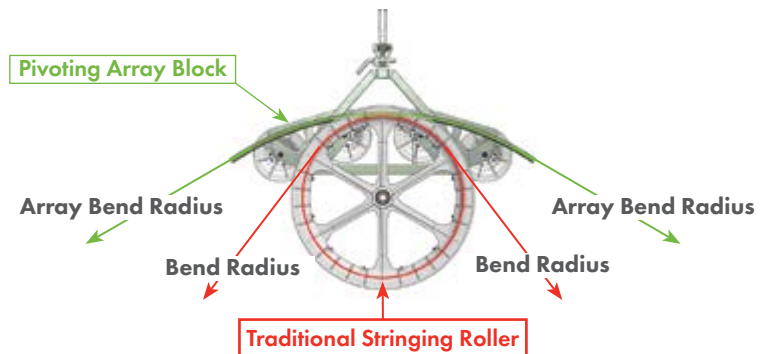

### Pivoting Array Blocks - TESMEC

Array blocks are used for conductors with large bending radius.

- **Lightweight - Dimension:**  
Vertical dimension is less than half of the height of a standard pulley
- **Easy Handling & Transportation:**  
The compact design allows easy handling and prevents damaging during the transportation
- Refer page J46 for detailed information



- **No diameter limitation:**  
Double pivoting frame allows it to move according to the line geometry by adjusting up to horizontal position, for an infinite bending radius
- **Special Sectors:**  
Manufactured with anti wear material, tested and released in cooperation with Milan Politecnico
- **Integrated Earthing Device:**  
Earthing device (if requested) is integrated into the frame, to prevent any possible impact or damaging during transport
- **Matchable with Standard Block:**  
Groove 68 mm and groove 95 mm as per standard pulley are both available
- **Fully Compatible:**  
Headboards, swivels, ropes, cover joints and all other equipment used for standard pulleys are fully compatible with array blocks
- **High Center of Gravity:**  
Easier positioning at angles due to the centre

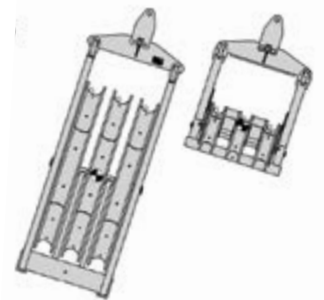

### Stringing Blocks

With more than 60 years of job-site use and thanks to a deep knowledge of job-site needs, Tesmec offers:

- Top quality at a competitive price
- Tailor made solutions
- 5 different materials and types for lining
- Available tandem and for helicopter stringing version on every standard model



### Earthing devices

#### Safety certified

In accordance with IEC TR 61328, Tesmec Earthing Devices are suitable for fault currents, lightning strikes and induced voltage rated at 20A for 20 cycles.

Several tests certified earthing devices properties. Available for drain current in equipotential system and for induced current.

Aluminium sectors with bearing conductive grease are also available as a special solution.



### Universal Stringing Roller - SPP

#### Part No. SPP-1A



- Suitable for distribution, ABC and some transmission applications
- Aluminium sheave
- Lightweight high strength heat treated aluminium
- Versatile attachment fittings include side and bottom tags and top ball socket fitting
- Side gate latch can be locked open
- Sheave is profile machined permitting precise sagging of conductor
- High quality permanently lubricated high temperature precision bearings

#### Part No. SPP-1A-DI

- Same Specifications as SPP-1A
- Ductile Iron sheave (SPP-1A-DI)
- Ideal for Pulling Steel conductor (e.g. 3/12 Steel) or steel catenary

Refer Pulling & Hauling section for Crossarm and Insulator brackets

Part No.	Sheave Material	Maximum Conductor OD (mm)	WLL (kg)	Weight (kg)	Bottom of Groove Diameter (mm)	Overall Height (mm)	Overall Width (mm)
SPP-1A	Aluminium	50	1130	4	110	370	205
SPP-1A-DI	Ductile Iron	50	1130	5	110	370	205

### Single Convertible Roller/Block - SPP

#### Part No. SPP-1B Series

- Extra large contoured throat for swivels, grips and splices
- Precision Earth bearings reduce pulling loads for accurate sagging
- Secured pins
- Durable and fully corrosion protected
- Urethane lined
- Socket fitting standard
- Helicopter Arm attachments available as an optional extra Part No. HELIHORN



400mm Helicopter Arm  
Part No. HELIHORN



Other sizes available on request

- C = Groove Width
- D = Bottom of Groove Diameter

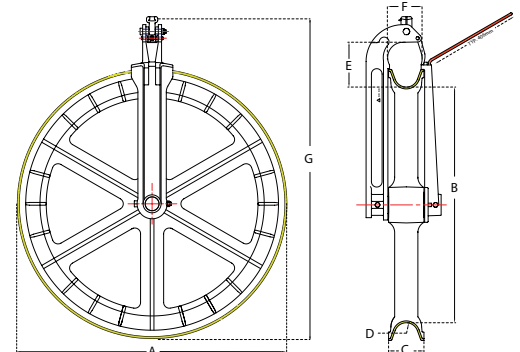

Part No.	Dimensions (mm)							Wt (kg)	WLL* (kg)
	Sheave				Throat		Frame		
	A	B	C	D	E	F	G		
SPP-1B-355-UL	420	355	60	18.5	89	76	600	11.8	2700
SPP-1B-460-UL	560	460	83	20.3	140	83	760	23.0	3650
SPP-1B-610-UL	710	610	90	22.9	152	85	940	31.5	4330
SPP-1B-710-UL	810	710	91	24.0	152	110	1030	36.4	6750

\* Working Load Limit (WLL) based on 3:1 Ultimate Tensile Strength

## Nylon Stringing Rollers/Blocks - TESMEC

Pulleys are assembled with generation high tensile nylon wheels.

This material combines in the best way lightness, performance and price.

Groove is shaped in conformity to IEC 61328 regulation for worldwide market.

All wheels are mounted on ball bearing and they are fully interchangeable.

Frame is made of galvanized steel. Frame and wheel can be easily detached for maintenance and reconfiguration.

No gap between wheels for safe handling, reducing size and weight.



### Single Nylon Stringing Blocks

Part No. CAS Series

C = Groove Width

D = Bottom of Groove Diameter

Part No.	Dimensions (mm)									Working Load (kN)	Wt (kg)
	A	B	C	D	E	F	G	H	I		
CAS528	16	24	83	560	935	248	660	210	240	40	40
CAS702	16	33	83	710	1275	408	822	228	240	40	63

### Two or Three Bundled Conductor Nylon Stringing Block

Part No. CAT Series

C = Groove Width

D = Bottom of Groove Diameter

Part No.	Dimensions (mm)										Working Load (kN)	Wt (kg)
	A	B	C	D	E	F	G	H	I	L		
CAT526	24	24	83	560	990	285	660	418	240	103	60	73
CAT700	32	33	88	710	1325	445	822	456	240	114	60	125

### Four or Five Bundled Conductors Nylon Stringing Blocks

Part No. CAQ Series

C = Groove Width

D = Bottom of Groove Diameter

Part No.	Dimensions (mm)										Working Load (kN)	Wt (kg)
	A	B	C	D	E	F	G	H	I	L		
CAQ527	30	33	83	560	1175	445	660	628	250	103	60	162
CAQ701	32	33	88	710	1380	445	822	684	250	114	60	187

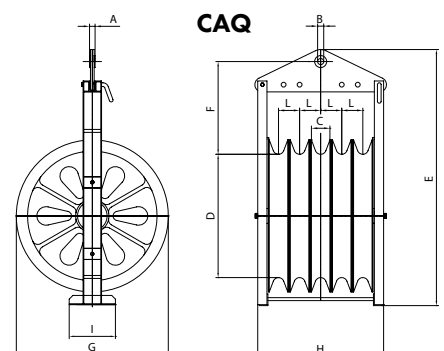
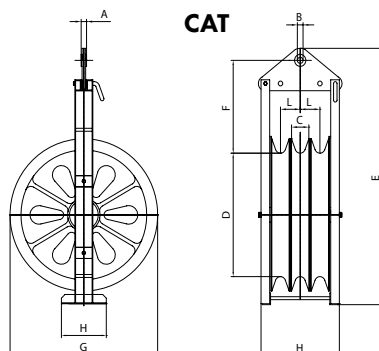
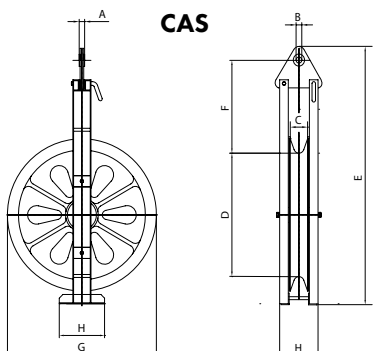

2, 3, 4 & 5 Bundle Head Boards for Nylon Rollers available. Contact TEN for further information



## Stringing Roller/Block - SPP

### Single Full Frame Roller/Block - SPP

#### Part No. SPP-1D Series

- Extra large contoured throat for smooth passage of swivels, grips and splices
- Quick release detent pin for ease of operation, which exposes the entire sheave
- Precision Earth bearings reduce pulling loads for accurate sagging
- Secured pins
- Durable and fully corrosion protected
- Urethane lined
- Socket fitting standard

### Optional Earthing Device - SPP

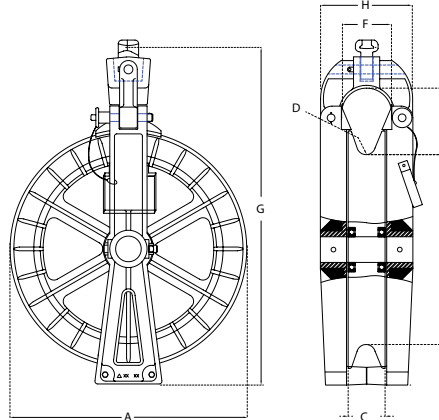

Available with Earthing Device  
Add Suffix "ED" to the Part No.

Part No	Dimensions (mm)								Wt (kg)	WLL* (kg)
	Sheave			Throat		Frame				
	A	B	C	D	E	F	G	H		
SPP-1D-355-UL	420	355	61	18.0	109	80	610	154	14.8	4050
SPP-1D-460-UL	560	460	82	20.5	142	104	775	197	27.0	5400
SPP-1D-610-UL	710	610	90	22.0	147	109	927	208	33.0	5400
SPP-1D-710-UL	810	710	91	25.4	147	109	1028	208	39.0	6750
SPP-1D-770-UL	870	770	90	27.5	142	109	1082	208	44.0	6750

\* Working Load Limit (WLL) based on 3:1 Ultimate Tensile Strength



## Fittings - Ball Clevis - SPP

### Ball Clevis Socket Fittings

#### Part No. Various

- Suitable for SPP-1A / 1B / 1D
- 70kN WLL

Part No	BC-70	BEL-70	BHL-70	BYC-120
Description	Ball Clevis	Oval Eye Ball	Safety Hook	Y Ball Clevis
Weight (kg)	0.55	0.4	0.55	0.85

## Stringing Rollers/Blocks - TESMEC

### Single Stringing Roller/Block

Part No. CAS Series

Neoprene



Nylatron



Aluminium



The CAS wheel is made of aluminium alloy mounted on ball bearings.

The groove is lined with a neoprene ring or by wear-proof interchangeable nylatron or aluminium sectors.

The frame is made of galvanized steel. Three types of connections available: fixed (B), swivel-type (C), and hook with safety lock (D).

Earthing device or complete conductive sheaves available upon request.

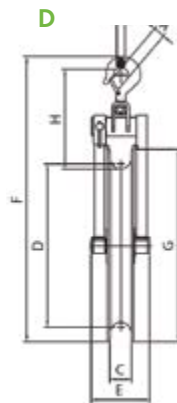
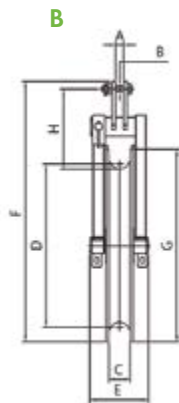
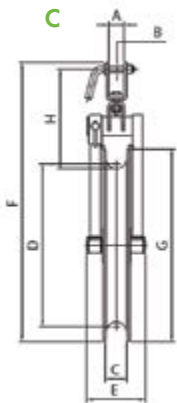

CCA Anti-fleeting devices available upon request. See page J45

Part No.			Type of Connection	Dimensions (mm)								Working Load (kN)	Wt (kg)
Roller Groove Lining				A	B	C	D	E	F	G	H		
Neoprene	Nylatron	Aluminium											
-	CAS200	CAS207	C	26	16	50	250	145	482	330	175	27	7
-	CAS201	CAS208	D	25	19	50	250	145	490	330	175	27	7
CAS300	CAS301	CAS308	B	26	18	54	350	150	595	440	200	23	11
CAS302	CAS303	CAS309	C	35	18	54	350	150	640	440	225	23	12
CAS304	CAS305	CAS310	D	31	30	54	350	150	630	440	235	23	12
CAS600	CAS601	CAS632	B	26	20	68	650	186	996	775	260	33	28
CAS602	CAS603	CAS638	C	40	20	68	650	186	1052	775	315	33	29
CAS604	CAS605	CAS639	D	32	33	68	650	186	1087	775	330	33	30
CAS606	CAS607	CAS644	B	26	20	95	650	218	1010	775	275	40	32
CAS608	CAS609	CAS645	C	40	20	95	650	218	1062	775	330	40	33
CAS610	CAS611	CAS646	D	32	33	95	650	218	1097	775	345	40	34
CAS800	CAS801	CAS843	B	26	20	68	800	186	1101	880	260	40	32
CAS802	CAS803	CAS835	C	40	20	68	800	186	1157	880	315	40	33
CAS804	CAS805	CAS836	D	32	33	68	800	186	1192	880	330	40	34
CAS806	CAS807	CAS857	B	26	20	95	800	218	1125	893	275	40	38
CAS808	CAS809	CAS852	C	40	20	95	800	218	1180	893	330	40	39
CAS810	CAS811	CAS858	D	32	33	95	800	218	1215	893	345	40	40
-	CAS002	CAS012	B	26	20	95	1000	218	1335	1100	275	40	49
-	CAS004	CAS013	C	40	20	95	1000	218	1387	1100	330	40	50
-	CAS006	CAS014	D	32	33	95	1000	218	1422	1100	345	40	51
-	CAS027	-	B	25	24	130	1200	310	1824	1393	500	90	110
-	CAS034	-	B	25	24	130	1500	310	2124	1670	500	90	155

### Two or Three Bundled Conductor Stringing Blocks

#### Part No. CAT Series

- The wheels are made of aluminium alloy
- The lateral wheels are mounted on ball bearings with grooves lined with neoprene ring
- The central wheel is mounted on double-row ball bearings with grooves made up of wear-proof interchangeable nylatron sectors
- The frame is made of galvanized steel
- Blocks are supplied with fixed connection.
- Earthing device or complete conductive sheaves are available upon request.

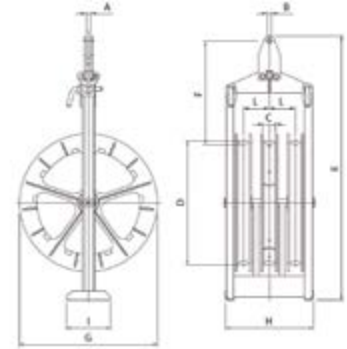

Part No.			Dimensions (mm)										Working Load (kN)	Wt (kg)
Nylon/Neoprene	Nylon	Aluminium	A	B	C	D	E	F	G	H	I	L		
CAT612	CAT648	CAT622	25	24	68	650	1430	580	775	500	250	145	50	110
CAT613	CAT676	CAT654	25	24	95	650	1430	580	775	572	250	175	70	130
CAT812	CAT912	CAT894	25	24	68	800	1530	580	880	500	250	145	70	125
CAT813	CAT848	CAT874	25	24	95	800	1540	580	893	572	250	175	70	160
-	CAT007	-	25	24	95	1000	1740	580	1100	572	250	175	70	198
-	CAT029	-	25	24	133	1200	2060	580	1393	722	250	222	90	270
-	CAT035	-	25	24	133	1500	2330	580	1670	722	250	222	90	320



### Four & Five Bundled Conductor Stringing Blocks

#### Part No. CAQ Series

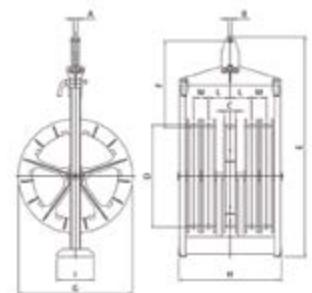

Part No.			Dimensions (mm)										Working Load (kN)	Wt (kg)	
Nylon/Neoprene	Nylon	Aluminium	A	B	C	D	E	F	G	H	I	L			M
CAQ614	CAQ666	CAQ623	25	24	68	650	1440	595	775	700	250	145	100	50	148
CAQ615	CAQ667	CAQ656	25	24	95	650	1440	595	775	826	250	175	130	70	190
CAQ814	CAQ818	CAQ856	25	24	68	800	1540	595	880	700	250	145	100	70	180
CAQ815	CAQ881	CAQ827	25	24	95	800	1540	595	893	826	250	175	130	70	225
-	CAQ008	-	25	24	95	1000	1750	595	1100	826	250	175	130	70	270
-	CAQ030	-	25	24	133	1200	2115	595	1393	1081	250	222	177	90	320
-	CAQ036	-	25	24	133	1500	2383	595	1670	1081	250	222	177	90	405

\*Central sheave nylatron - lateral sheaves nylatron IEEE



## Detachable Two or Three Bundled Stringing Block

### Part No. CST Series

- The block are ideal for stringing two or three bundled conductors.
- The pulleys are made up of a special galvanized steel frame and three single pulleys
- The single pulleys can be used separately
- The wheels are made of aluminium alloy mounted on ball bearings
- The lateral wheels have the groove lined with a neoprene ring
- The central wheel has the groove made up of wear-proof interchangeable nylatron sectors
- The pulleys are supplied with fixed connection

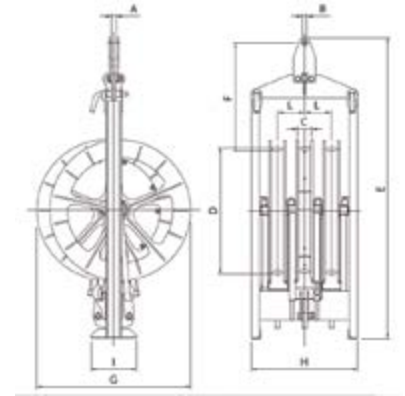

Part No.		Dimensions (mm)										Working Load (kN)	Wt (kg)
Nylon/Neoprene	Nylon	A	B	C	D	E	F	G	H	I	L		
CST600	CST604	25	24	68	650	1563	600	846	580	250	148	40	151
CST601	-	25	24	95	650	1667	600	846	671	250	178	60	166
CST800 CST807*	-	25	24	68	800	1758	600	951	580	250	148	60	166
CST801	CST808	25	24	95	800	1758	600	964	671	250	178	60	190
-	CST001	25	24	95	1000	1995	600	1171	671	250	178	67	228

\*All neoprene lining

## Helicopter Stringing Block

### Part No. CES Series

Ideal for stringing a pilot rope by helicopter

The pilot rope is automatically positioned in the (central) wheel. Special guides ensure the correct positioning of the rope during stringing operations.

- The wheels are made of aluminium alloy mounted on ball bearings
- The lateral wheels have the groove lined with a neoprene ring
- The central wheel has the groove made up of wear-proof interchangeable nylatron sectors
- The frame is made of galvanized steel
- The pulleys are supplied with fixed connection
- Earthing device or complete conductive sheaves are available upon request

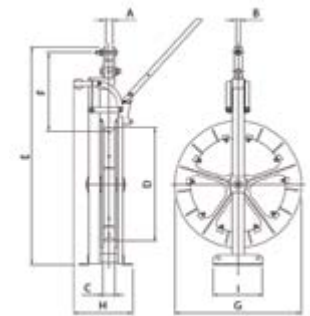

Part No.			Dimensions (mm)									Working Load (kN)	Wt (kg)
Nylon/Neoprene	Nylon	Aluminium	A	B	C	D	E	F	G	H	I		
CES604	CES600	-	41	20	68	650	1345	490	775	362	300	40	62
-	CES601	CES618	41	20	95	650	1345	500	775	376	300	40	68
-	CES800 CES811 * CAT875 *	-	41	20	68	800	1440	480	880	362	300	40	68
-	CES801 CES831 *	-	41	20	95	800	1460	500	893	376	300	40	74
-	CES001	-	41	20	95	100	1665	500	-	376	300	67	93
-	CES005	-	41	24	133	1200	2005	558	-	462	600	90	180
-	CES008	-	41	24	133	1500	2310	570	-	462	600	90	215

\*All sheaves with IEEE sectors

### Helicopter Stringing Block

#### Part No. CET Series

- The wheels are made of aluminium alloy mounted on ball bearings
- The lateral wheels have the groove lined with a neoprene ring
- The central wheel has the groove made up of wear-proof interchangeable nylatron sectors
- The frame is made of galvanized steel
- The pulleys are supplied with fixed connection
- Earthing device or complete conductive sheaves are available upon request

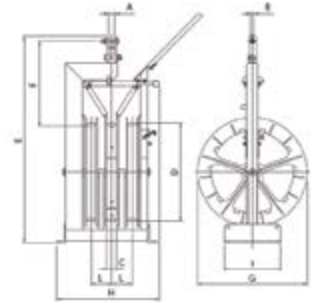

Part No.			Dimensions (mm)										Working Load (kN)	Wt (kg)
Nylon/Neoprene	Nylon	Aluminium	A	B	C	D	E	F	G	H	I	L		
CET602	CET610*	-	41	20	68	650	1345	605	775	730	400	145	60	142
CET603	-	CET608	41	20	95	650	1430	610	775	810	400	175	60	164
CET802	CET821 CET807*	CET829	41	20	68	800	1582	610	880	730	400	145	60	158
CET803	CET820 CET812*	CET806	41	20	95	800	1582	610	893	810	400	175	60	179
-	CET002	-	41	20	95	1000	1805	629	1100	830	400	175	67	235
-	CET006	-	41	20	133	1200	2100	640	1393	1005	500	222	90	315
-	CET009	-	41	20	133	1500	2405	640	1670	1005	500	222	90	362

\*All sheaves with IEEE sectors

### Helicopter Stringing Block

#### Part No. CEQ Series

- The wheels are made of aluminium alloy mounted on ball bearings
- The lateral wheels have the groove lined with a neoprene ring
- The central wheel has the groove made up of wear-proof interchangeable nylatron sectors
- The frame is made of galvanized steel
- The pulleys are supplied with fixed connection
- Earthing device or complete conductive sheaves are available upon request

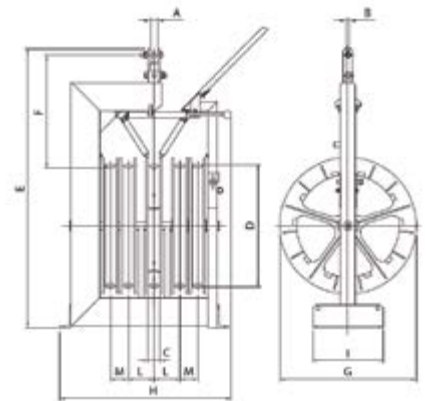

Part No.			Dimensions (mm)											Working Load (kN)	Wt (kg)
Nylon/Neoprene	Nylon	Aluminium	A	B	C	D	E	F	G	H	I	L	M		
CEQ609	CEQ614**	-	41	20	68	650	1580	641	775	906	400	145	100	60	228
CEQ612	-	-	41	20	95	650	1625	670	775	1130	400	175	130	60	258
CEQ808	CEQ813**	CEQ818	41	20	68	800	1750	670	880	910	400	145	100	60	250
CEQ809	CEQ819**	-	41	20	95	800	1750	647	893	1130	400	175	130	60	280
-	CEQ003	-	41	20	95	1000	1945	670	1100	1130	400	175	130	67	360

\*\*Central nylatron - lateral nylatron IEEE

## Tandem Stringing Roller/Blocks

### Part No. CAM Series



The blocks are ideal for stringing single, two or three bundled conductors.

The pulleys are made up of a special galvanized steel frame and three single pulleys. The single pulleys can be used separately. The wheels are made of aluminium alloy mounted on ball bearings.

The lateral wheels have the groove lined with a neoprene ring.

The central wheel has the groove made up of wear-proof interchangeable nylatron sectors.

The pulleys are supplied with fixed connection.

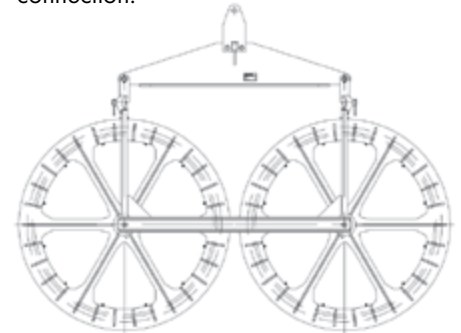

Part No.	Based On	Wheel Ø (mm)	Groove (mm)	Working Load (kN)	Wt (kg)
CAM210	CAS200	250	50	33	25
CAM618	CAS602	650	68	60	72
CAM631	CAT613	650	95	60	290
CAM636	CAT612	650	68	70	270
CAM640	CAS607	650	95	60	87
CAM662	CAS601	650	68	60	91
CAM665	CAS606	650	95	60	98
CAM669	CAS608	650	95	60	100
CAM849	CAS802	800	68	60	92
CAM892	CAS801	800	68	60	89
CAM896	CAS807	800	95	60	118
CAM907	CAE906	800	95	100	632
CAM015	CAS002	1000	95	60	135
CAM023	CAS024	1000	95	60	166
CAM028	CAS027	1200	130	90	250
CAM031	CAS027	1000	95	90	175
CAM032	-	1200	130	120	312
CAM042	CAE041	1000	95	80	835
CEM619	CES600	650	68	60	239
CEM827	CET8XX	800	95	80	415
CEM828	CES801	800	95	80	205
CEM830	CET829	800	68	80	404



## Earthing Devices for Stringing Blocks - TESMEC

### Part No. CCA Series

Earthing devices can be supplied on single, bundle and helicopter wheels manufactured by Tesmec.

Earthing devices complies with IEC TR 61328 REV.3 requirement 20 kA for 20 cycles.



Nylon Stringing Blocks		
Stringing Blocks Part No.	Dia 560	Dia 700
CAS	MTX140	MTX143
CAT	MTX138	MTX141
CAQ	MTX139	MTX142



Aluminium Stringing Blocks						
Stringing Blocks Part No.	Dia 400-500	Dia 650		Dia 800		Dia 1000
		68 Narrow Groove	95 Wide Groove	68 Narrow Groove	95 Wide Groove	95 Wide Groove
CAS	MTX120	MTX079	MTX079	MTX079	MTX079	MTX081
CAT	-	MTX101	MTX122	MTX129	MTX102	MTX103
CAQ	-	MTX104	MTX105	MTX130	MTX131	MTX106
CES	-	MTX090	MTX090	MTX090	MTX090	MTX089
CET	-	MTX107	MTX108	MTX134	MTX135	MTX109
CEQ	-	MTX110	MTX111	MTX132	MTX133	MTX112

## Anti-fleeting Devices - TESMEC



Bundled Stringing Blocks

### Part No. CCA Series

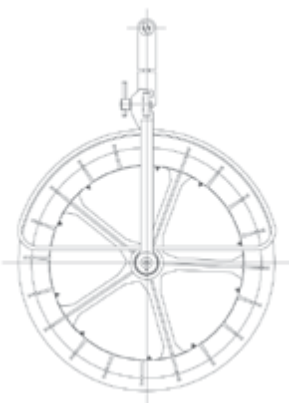

Single Stringing Blocks	
Included	For D=
CCA300	250
CCA600	350
CCA400	650
CCA400	400
CCA500	500
CCA800	800
CCA000	1000
CCA001	1200
CCA009	1500

Bundle Stringing Blocks	
Included	For D=
CCA601	250
CCA801	350
CCA007	650
CCA400	400
CCA400	500
CCA500	800

### TESMEC

## Pivoting Array Blocks - TESMEC

### Single Conductor Pivoting Array Blocks

#### Part No. RUS

- Lightweight & compact
- No diameter limitation
- Easy handling & transportation

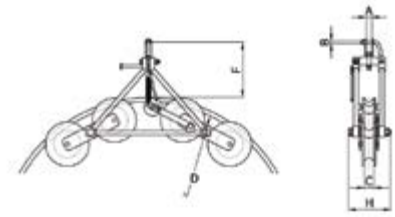

Part No.		Dimensions (mm)									Working Load (kN)	Wt (kg)
Fibreglass	Aluminium	A	B	C	D	E	F	G	H	I		
RUS005	RUS026	40	20	68	1600	810	393	1350	295	305	40	42
RUS007	RUS027	40	20	68	1820	800	367	1470	295	305	40	48

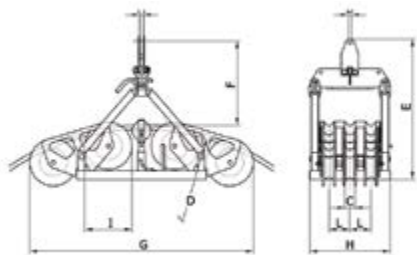

### Two or Three Bundled Conductors Pivoting Array Blocks

#### Part No. RUT

Part No.		Dimensions (mm)										Working Load (kN)	Wt (kg)
Cast Iron + Fibreglass	Cast Iron + Aluminium	A	B	C	D	E	F	G	H	I	L		
RUT013	RUT014	25	24	68	3120	1035	580	1495	560	305	145	60	183
RUT015	RUT016	25	24	95	3260	1035	580	1600	640	326	175	60	200



### Four or Five Conductors Pivoting Array Blocks

#### Part No. RUQ

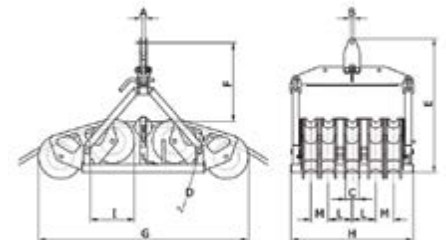

Part No.		Dimensions (mm)											Working Load (kN)	Wt (kg)
Cast Iron + Fibreglass	Cast Iron + Aluminium	A	B	C	D	E	F	G	H	I	L	M		
RUQ005	RUQ026	25	24	68	3120	1035	580	1495	760	305	145	100	60	255
RUQ007	RUQ027	25	24	95	3260	1035	580	1600	900	326	175	130	60	280

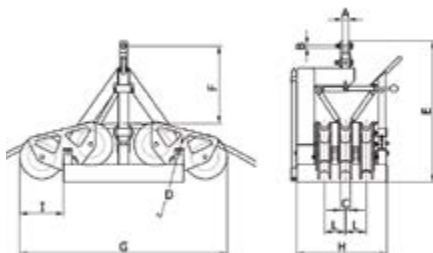

### Two or Three Conductors Pivoting Array Helicopter Blocks

#### Part No. RET

Part No.		Dimensions (mm)										Working Load (kN)	Wt (kg)
Cast Iron + Fibreglass	Cast Iron + Aluminium	A	B	C	D	E	F	G	H	I	L		
RET002	RET003	40	21	68	3390	980	540	1445	665	305	145	60	196
RET004	RET005	40	21	95	3530	980	540	1550	745	326	175	60	215

### TESMEC



Special models with different characteristics are available on request

## Head Boards - TESMEC

Designed to connect a pulling rope, (24mm Max) with 2 or 3 bundled conductors.

The equipment includes the necessary rope lengths and swivels. Quantity and models are indicated in the following tables.

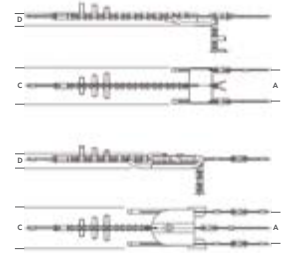

### 2 or 3 Conductors Fixed Head Boards

#### Part No. RFB-RFT Series

Part No.	Dimensions (mm)			Working Load (kN)	Wt (kg)	For Stringing Blocks		Swivel Joints		Steel Rope Section Ø 18mm	Phase Type
	A	C	D			Standard	Helicopter	GGT020	GGT030		
RFB020	292	335	144	93	98	CAT506 CAT612 CAT812 CST500 CST600 CST800	CET602 CET802	2	1	2 x 3.5m	2 Conductors
RFB370	292	335	144	120	100			3	1	3 x 3.5m	3 Conductors
RFT030	292	335	144	93	104						
RFT380	292	335	144	120	107						
RFB040	348	390	144	93	100	CAT613 CAT813 CAT007 CST601 CST801 CST001	CET603 CET803 CET002	2	$\frac{1}{1 \times \text{GGT040}}$	2 x 3.5m	2 Conductors
RFB390	348	390	144	150	103			3	$\frac{1}{1 \times \text{GGT040}}$	3 x 3.5m	3 Conductors
RFT050	348	390	144	93	107						
RFT400	348	390	144	150	110						

Contact TEN for Head Boards for Nylon Rollers

### 2, 3 or 4 Conductors Balancing Head Boards

#### Part No. RBB-RBT Series

Part No.	Dimensions (mm)			Working Load (kN)	Wt (kg)	For Stringing Blocks		Swivel Joints		Steel Rope Section Ø 18mm	Phase Type
	A	C	D			Standard	Helicopter	GGT020	GGT030		
RBB001	292	365	160	93	135	CAT506 CAT612 CAT812 CST500 CST600 CST800	CET602 CET802	2	1	1 x 30m	2 Conductors
RBB580	292	365	160	120	140			3	1	1 x 30m 1 x 15m	3 Conductors Balancing 1-3
RBT010	292	365	160	93	157			3	1	1 x 30m 1 x 15m	3 Conductors Balancing 1-2
RBT590	292	365	160	120	162						
RBT260	292	365	160	93	157						
RBT680	292	365	160	120	162						
RBB020	348	415	176	93	143	CAT613 CAT813 CAT007 CST601 CST801 CST001	CET603 CET803 CET002	2	$\frac{1}{1 \times \text{GGT040}}$	1 x 30m	2 Conductors
RBB690	348	415	176	150	148			3	$\frac{1}{1 \times \text{GGT040}}$	1 x 30m 1 x 15m	3 Conductors Balancing 1-3
RBT030	348	415	176	93	165			3	$\frac{1}{1 \times \text{GGT040}}$	1 x 30m 1 x 15m	3 Conductors Balancing 1-2
RBT560	348	415	176	150	170						
RBT140	348	415	176	93	165						
RBT700	348	415	176	150	170						



#### Part No. RBQ Series

Designed to connect a pulling rope, (28mm Max) with 4 bundled conductors.



Part No.	Dimensions (mm)				Working Load (kN)	Wt (kg)	For Stringing Blocks		Swivel Joints		Steel Rope Section Ø 18mm
	A	B	C	D			Standard	Helicopter	GGT020	GGT030	
RBQ710	100	292	540	150	120	193	CAQ614 CAQ814	CEQ609 CEQ808	4	1	2 x 30m
RBQ720	130	340	648	160	150	208	CAQ615 CAQ815	CEQ612 CEQ809	4	$\frac{1}{1 \times \text{GGT040}}$	2 x 30m
RBQ080	130	340	650	175	250	230	CAQ008	CEQ003			

Additional Fixed & Balancing Head Boards to suit a wide range of 4 & 5 bundle rollers available. Contact TEN for further information



### TESMEC



## Conductor Chairs & Cars

### Conductor Cars For Single Conductor Lines - TESMEC

#### Part No. CRS320

This conductor car is manufactured of light aluminium alloy and allows one person to cross or to inspect single conductor lines. Complete with two aluminium neoprene lined, metre counter and stationary brake.

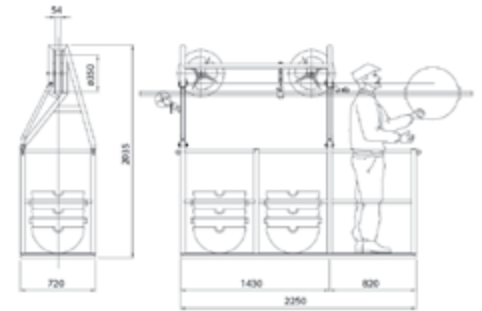

Capacity (kg)	150
Weight (kg)	75

### HIATCO

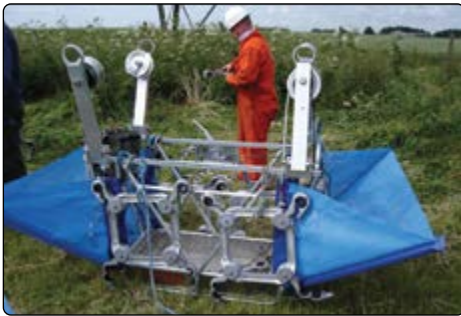

### Conductor Spacer Chair – Hiatco

#### Part No. HSSC-Series

For transporting line-workers to carry out maintenance & repair on conductors mid-span. The standard spacer chair frame is manufactured from lightweight aluminium alloy 6082T6 using standard box and circular sections as well as non-slip flooring.

#### Features

- Lightweight aluminium cage
- Hand brake with lock feature
- 250kg WLL (Proof load 375kg)
- Test cert supplied
- 4 harness anchor points
- Battery powered option\*

Part No	WLL (kg)	Dimensions Including Support Arms (mm)			Wt (kg)
		Width	Depth	Height	
HSSC-P*	250	1360	630	1530	80
HSSC	250	1360	630	1530	60

### TESMEC



Special models are available upon request, including motorised.

### Inspection Conductor Car - TESMEC

#### Part No. CRQ530

- Two detachable brakes
- Metre counter
- Earthing roller
- Safety rope

Aluminium alloy conductor cars suitable for construction and inspection of bundled line that allow two workers to work on two or four bundled conductors line.

Conductor car is able to pass over spacers

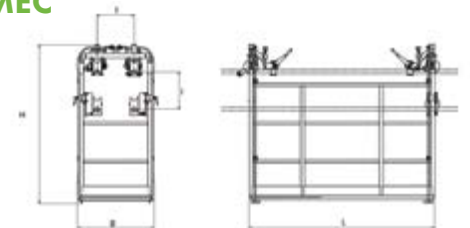

Configuration with only two axles leave more space for operators and line equipment. Conductor cars are equipped with brakes, safety rope and metre counter.

Part No.	Dimensions (mm)				Capacity (kN)	Wt (kg)
	B	H	L	I		
CRQ530	818	1650	2000	400	250	90

Special models are available upon request, including motorised  
Contact TEN for further information

### HIATCO



## Aluminium Structures

### Working Platforms – Hiatco

#### Part No. HWP Series

Utilised for Line-workers to gain access on towers to carryout maintenance & repair on conductors and tower hardware.

#### Features

- All box sections, angles & plates of the platform are built from structural aluminium 6082T6
- Variety of lengths and configurations available, including folding and telescopic ends
- Specially extruded aluminium non-slip flooring & toe-board
- Fall arrest support brackets and safety wire
- Load test certificate supplied for each platform

Platform Length (m)			Centre Section qty Length & (WLL)	End Section qty Length & (WLL)	Telescopic Section Length & (WLL)	Weight of Safety Wires & Brackets (kg)	Total Weight (kg)
Total	Extended	Retracted					
6.0	Fixed	Fixed	1 x 6.0m (200kg)	Not Required	Not Required	10	210
7.0	Fixed	Fixed	2 x 3.5m (75kg)	NA	NA	c/w centre stirrups	150
9.0	Folding ends		1 x 6.0m (150kg)	Not Required	2 x 1.5m (35kg)	NA	220
12.0	Fixed	Fixed	1 x 1.5m (60kg)	2 x 5.0m (170kg)	Not Required	20	420
16.0	Fixed	Fixed	1 x 6.0m (200kg)	2 x 5.0m (170kg)	Not Required	25	565
16.0	15.5	10.3	1 x 3.1m (145kg)	2 x 3.5m (125kg)	2 x 3.8m (80kg)	25	580
19.0	18.5	12.9	1 x 6.0m (200kg)	2 x 3.5m (125kg)	2 x 3.8m (80kg)	30	635
21.0	20.3	14.1	1 x 6.0m (200kg)	2 x 4.0m (140kg)	2 x 4.2m (80kg)	30	670

### TESMEC



## Working Platforms - TESMEC

#### Part No. PLL Series

The working platforms have trapezoidal section and are made of aluminium alloy. For modular use, the platforms extra sling and anti-fall barrier kit are required for each specific length.

All the platforms are provided with single side anti fall barrier. Special working platforms are available upon request.

- Detachable wide range
- Several frame options available

Available Options	
PYB001	Special track For hydraulic press trolley
PYC002	Hydraulic press trolley
PYDXXX	Double side anti-fall barrier

Part No.	Total Length (m)	Lateral Section Length (m)	Central Section Length (m)	Intermediate Section Lengths (m)	Working Load at the two ends (kg)	Wt (kg)
PLL004	7	3.5+3.5	-	-	300	65
PLL302	8	4+4	-	-	300	75
PLL308	9	4.5+ 4.5	-	-	300	85
PLL306	10	5+5	-	-	300	95
PLL303	11	5.5 +5.5	-	-	300	105
PLL311	12	6+6	-	-	300	107
PLL300	12	3.5+3.5	5	-	300	110
PLL600	16	3.5+3.5	5	2+2	300	150
PLL901	18	4.5+ 4.5	4.5+4.5	-	300	180
PLL909	20	5+5	5+5	-	300	190
PLL900	22	5.5 +5.5	5.5+5.5	-	300	200
PLL905	24	6+6	6+6	-	300	228
PLL907	26	5+5+5+5	6	-	300	240

## Anchoring Ladders - TESMEC

### Part No. SCA Series



Specifically designed for anchoring works.

The ladders are made of light aluminium alloy, with anti-slippery rungs and with galvanized steel suspension hooks.

The ladders are supplied with a supplementary swivel hook to be located on the conductor, which allows the ladder to be used in horizontal position. The ladders are available with triangular or trapezoidal section.

- Lightweight platform
- Easy to handle
- Replacement sections available

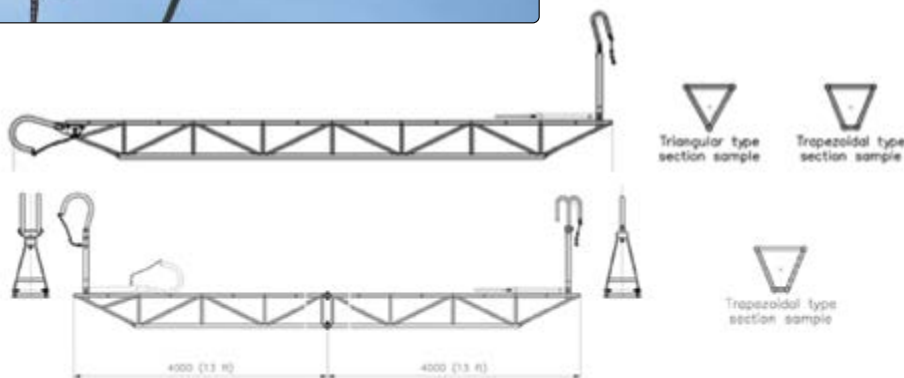

Part No.	Length (m)	Section Length (m)	Working Load (kg)	Linear Wt (kg/m)	Section
SCA700	4	4	150	4	Triangular
SCA800	6	6	150	4	Triangular
SCA801	6	4+2	150	4	Triangular
SCA900	8	4+4	150	4	Triangular
SCA400	3.5	3.5	300	4.7	Trapezoidal
SCA401	4.5	4.5	300	4.7	Trapezoidal
SCA500	6.5	4.5+2	300	4.7	Trapezoidal
SCA600	8	4+4	300	4.7	Trapezoidal



SDG010



SDG009



SDG018



SDG025



SDG019

Part No.	Special Models and Lengths Available on request
SDG010	Standard swivel hook conductor side
SDG009	Standard swivel hook with roller (conductor side)
SDG018	Swivel suspension hook (tower side)
SDG025	Double swivel suspension hook (tower side)
SDG019	Double hook swivel (conductor side)



## Suspension Ladders - TESMEC

### Part No. SCS Series

Specifically designed for suspension works. The ladder is made of light aluminium alloy, fitted with anti-slippery rungs, with a special track for the anti-fall device and with a galvanized steel supporting hook.

- PPE system
- Modular and lightweight
- SCS LADDERS WITH SDA ANTI-FALL DEVICE Comply with 89/686/CEE

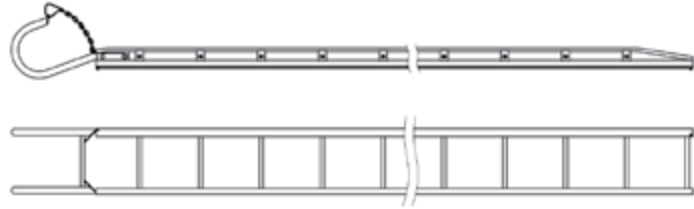

Part No.	Length (m)	Section Length (m)	Working Load (kg)	Linear Wt (kg/m)	Anti-fall Device (model not incl.)
SCS100	3.5	3.5	300	3.8	SDA021
SCS200	4.5	4.5	300	3.8	SDA021
SCS306	5	5	300	3.8	SDA021
SCS300	6	6	300	3.8	SDA021
SCS301	6	4+2	300	3.8	SDA021
SCS302	8	4+4	300	3.8	SDA021



## Double Swivel Ladder Hook - TESMEC

### Part No. SDG015

Special models with different lengths are available upon request.

#### Available Options

SDG015	360° Double swivel hook
--------	-------------------------

Ladder hooks swivel 360° for maneuvering into difficult spots

## Anti-Fall Devices - TESMEC

### Part No. SDA Series

Personal protective devices to prevent the operator falling. The device is self-guided and self-locking, running on a special rigid track, constructed of light aluminium alloy. Supplied with a polyamide mini energy-absorber and safety spring catch to connect it to the safety harness.

It allows the proper movement of the operator along the ladder and at the same time protecting them from falling. End stroke devices are provided in order to avoid that the anti-fall device running from the anchoring track.

- Zero snagging with self guiding and locking
- Energy Absorber
- Harness Safety spring catch
- Comply with 89/686/CEE



#### Special Models with Different Lengths Available on request

Part No.	Working Load (m)	Nylon Rope Length (mm)	Wt (kg)
SDA021	100	300	1
SDA022	100	300	1

## Aluminium Derricks - TESMEC

### Part No. FAL Series

- Light design
- Swivel head and base
- Special models can be designed on demand

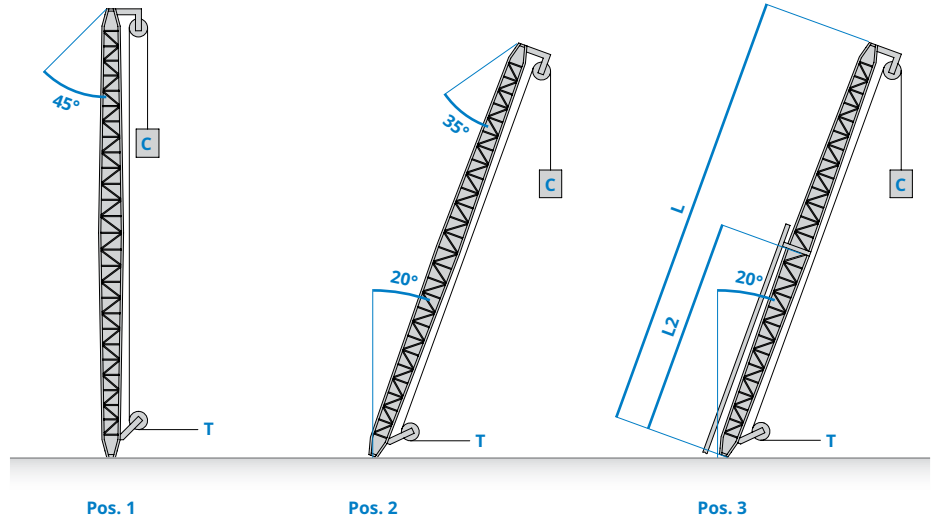

Part No.	"L" Total Length (m)	"L2" Section Lengths (m)	Max lifting load (kN)			Wt (kg)	Snatch blocks (not included)		Anchoring Ropes (n° 4 for each)
			Pos. 1 0°	Pos. 2 20°	Pos. 3 20°		Upper service snatch blocks	Upper service snatch blocks	
FAL001	8	4+4	6,5	5	1,5	40	CZA101	CZA101	ALT046
FAL010	12	4+4+4	6,5	5	1,5	65	CZA010	CZA101	ALT047
FAL020	8	4+4	10	8	2	45	CZA010	CZA101	ALT046
FAL030	10	4+2+4	10	8	2	60	CZA010	CZA101	ALT046
FAL040	12	4+4+4	10	8	2	70	CZA010	CZA101	ALT047
FAL050	8	3+2+3	12,5	10	2,5	50	CZA030	CZA101	ALT046
FAL060	12	4+4+4	12,5	10	2,5	80	CZA030	CZA101	ALT047
FAL070	16	5+6+5	12,5	10	2,5	110	CZA030	CZA101	ALT048
FAL080	12	4+4+4	19	15	3,5	100	CZA140	CZA030	ALT043
FAL090	16	5+6+4	19	15	3,5	130	CZA140	CZA030	ALT044
FAL100	18	6+6+6	19	15	3,5	180	CZA140	CZA030	ALT045
FAL110	20	5+5+5+5	19	15	3,5	200	CZA140	CZA030	ALT045
FAL120	12	4+4+4	25	20	4	120	CZA140	CZA030	ALT156
FAL130	16	4+4+4+4	25	20	4	160	CZA140	CZA030	ALT147
FAL140	20	5+5+5+5	25	20	4	220	CZA140	CZA030	ALT015
FAL150	12	6+6	31	25	5	150	CZA380	CZA140	ALT156
FAL160	16	5+6+5	31	25	5	200	CZA380	CZA140	ALT147
FAL170	18	6+6+6	31	25	5	230	CZA380	CZA140	ALT015
FAL180	20	5+5+5+5	31	25	5	250	CZA380	CZA140	ALT015
FAL190	16	5+6+5	50	40	8	300	CZA350	CZA340	ALT155
FAL200	18	6+6+6	50	40	8	330	CZA350	CZA340	ALT155
FAL210	22	5+6+6+5	50	40	8	400	CZA350	CZA340	ALT017

Standard derricks with external rope passage, available on request with internal rope passage.

## Support Structure - TESMEC

### Part No. PIL Series

Light aluminium alloy supporting structure for erection of barriers and netting for the protection of roads, railways, channels and line crossings.

- Modular
- Light and strong

**PIL**
**PXT004**
**PXT002**
**PXB006**

Part No.	Length (mm)	Section	Capacity (kN)	Mass (kg)
<b>PIL100</b>	2000	Triangular	10	7.5
<b>PIL101</b>	4000	Triangular	10	14
<b>PIL500</b>	2000	Square	10	9.5
<b>PIL501</b>	4000	Square	10	18.5

### Options

Description	FOR SQUARE SECTION	FOR TRIANGLE SECTION
Swivel light aluminium alloy head with pulley diameter 650mm	PXT001	PXT002
Steel head designed to carry wooden beams suitable crossing operations	PXT003	PXT004
Steel base	PXB005	PXB006



### TESMEC



### Monopole Ladders - TESMEC

#### Part No. SCP Series

Specifically designed for climbing circular or polygonal section poles. Standard lengths can be assembled to create the total length required. The ladder is made of light aluminium alloy, provided with anti-slip rungs and with special tracks for the anti-fall device.

- Perfect fit
- Sliding system

The ladder can be composed using the following elements:

Several standard sections:

- Quantity according to the total required height (SCP001)
- One self-supporting base for fixing the ladder to the pole without additional ground support (SCP003)

OR

- One self-supporting base section for fixing the ladder to the pole without additional ground support (SCP004)
- One terminal section, complete with anti-fall device, to be connected to any of the rungs of the last standard section, in order to adjust the final ladder length (SCP002)



#### Part No. SDA022

Anti-Fall device sold separately  
See page J51 for details

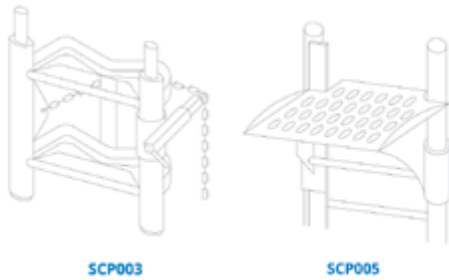

Part No.	Description	Section Length (m)	WLL (kg)	Wt (kg)	Anti-Fall Device
SCP001	Standard section	2.5	100	6.6	SDA022 (not included)
SCP002	Terminal section	2.5	100	7	SDA022 (not included)
SCP003	Self-supporting base	-	100	5	-
SCP004	Self supporting base section	2.5	100	7	Use one of the standard section
SCP005	Working platform	-	100	1.2	-

### TESMEC



### Support for working platform - TESMEC

#### Part No. ABS061

This equipment which is a support structure to connect a working platform onto the tower. It is provided with a self-support base and doesn't require anchoring devices on tower. It can be placed in every position on the tower. The device is designed to self adapt to the tower shape. It can support the weight of three operators.

Characteristics	
Working Load (kg)	500
Tower Dia. Range (mm)	450÷1700

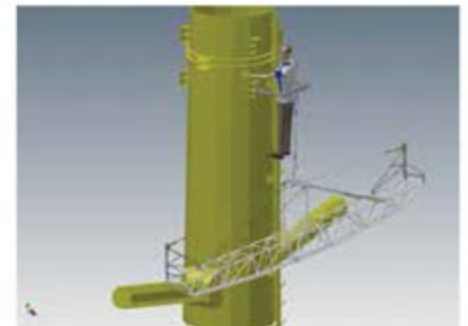

### Horizontal Ladder - TESMEC

#### Part No. SCA407

It's a device used to offer an easy passage from tower to the end of the tower's arms. It is provided with universal hook and a stabilizing system. The ladder is made of light aluminum alloy and can be detached in two section 3 + 1.5m

Characteristics	
Working Load (kg)	400
Length (m)	4.5 (3+1.5)

### Transmission Overhead PPE, Tools & Accessories

#### Conductor Lifter Hook

**Part No. DNS22-771**

Each unit is tagged showing the safe working load, proof-test date, and an identifying serial number.  
2,954kg (6,500 lb) safe working load.



Components may vary depending on state or territory requirements.

#### Rescue Kit - Tower

**Part No. TRRK**

##### Example Components List

- Storage backpack yellow
- 65m rope with sewn eye and triplock karabiner
- FDU100 Rescue Descender with triplock karabiner
- 50mm x 1200mm anchor sling
- 25mm x 1200mm round sling
- Rescue knife with extender and 2 alloy triplock karabiner
- Mechanical advantage retrieval system
- Cervical collar (optional)

Contact TEN with your Rescue Kit requirements



#### Wire Rope Slings 3.0T

**Part No. Various**

##### Superflex Steel Slings

- Supplied tested with NATA certificate
- Aluminium Ferrules
- 5:1 Safety Factor

Part No.	WLL (T)	Sling Length (m)
Four - 5-1	3.0	1.0
Four - 1.5	3.0	1.5
Five - 0-1	4.1	1.0
Five - 0-1.5	4.1	1.5
Five - 0-4	4.1	4.0
Five - 0-8	4.1	8.0



#### Soft Round Slings

**Part No. Various**

- Variable load bearing point for more even wear
- Ideal for choke lifting cylindrical objects
- Lifts smooth objects with out damage
- Lightweight and soft
- Reduced manual handling injuries
- High strength to weight ratio
- Load bearing fibres protected by the outer sleeve
- Tuff Tag webbing reinforced encapsulated compliance labels

Colour Code	Part No.	WLL (T)	Max Length (m)	Min Length (m)
Purple	E1000	1	60	0.5
Green	E2000	2	60	0.5
Yellow	E3000	3	60	0.5
Grey	E4000	4	60	1.0
Red	E5000	5	60	1.0
Brown	E6000	6	60	1.0
Blue	E8000	8	60	1.0

- Wide choice of lifting modes
- Certified to AS.4497

### ACSR Strippers

#### Part No. PSC-1

The Trimmer quickly and accurately removes the aluminium stranding from around the steel core of ACSR conductors in preparation for crimping the steel inner strand.

#### Features

- Made of an aluminium alloy
- Lightweight and durable
- Operates like a Tube Cutter
- Carry Case stores 11 bushings
- Standard Bushing sizes available (Sold separately)
- Bushings can be made to suit a wide range of ACSR conductors

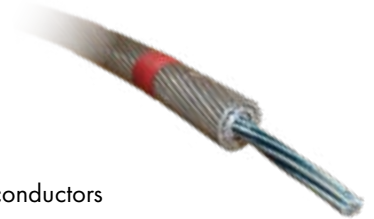

Bushing Holder



Bushing

Part No.	Kit Contains	Bushings to suit	Replacement Cutting Wheel #
PSC-1	Tool, bushing holder, (1) extra cutting wheel, and a plastic case that holds up to 11 bushings.	Cherry Grape Lemon Lychee Lime Mango Orange	TE54270
TE****	Bushing for use with PSC-1, *conductor to be specified	Olive Pawpaw	-

\*Other size bushings available on request

**PSC-2 Trimmer and Bushings available for larger size ACSR conductors**  
Please contact TEN for further information

### Steel Service Snatch Blocks - TESMEC

#### Part No. CZA

- Wheels mounted on ball bearings
- Special models can be designed on demand

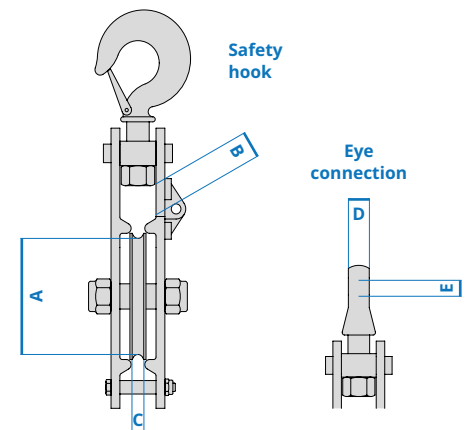

Steel Service Snatch Blocks Mod. CZA

Swivel Connection (Closed)	Dimensions (mm)					Working Load (kN)	Weight (kg)	
	A	B	C	D	E		Safety hook connection	Eye Connection
CZA370	108	40	15	20	17	17	5	4.9
CZA033	138	40	15	27	21	21	8	8.5
CZA141	185	55	30	30	26	26	12	12



### Anti-Lifting Automatic Release Pulley - TESMEC

#### Part No. CAA

The anti-lifting automatic release pulley is a special device that prevents the pulling rope lifting with respect to the theoretical line, specifically in case of towers with considerable height differences. It is equipped with an automatic release system to facilitate recovery operations. The wheel is made of galvanized steel and mounted on ball bearings; the pulley frame is made of galvanized steel.

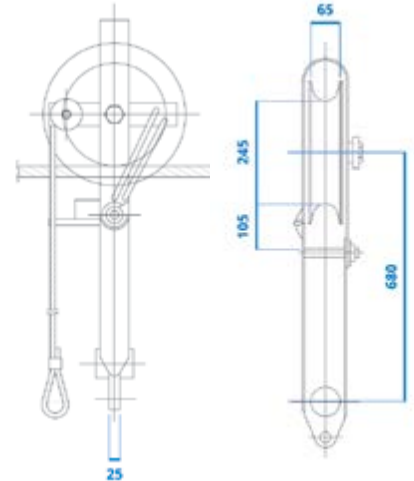

Working Load (kN)	27
Weight (kg)	20

### Lifting Tackles

#### Part No. TAP Series

- The lifting tackles are suitable For Ø 9mm steel ropes
- The wheels are mounted on ball bearings
- The frame is made of galvanized steel
- Rope and swivel joint not included

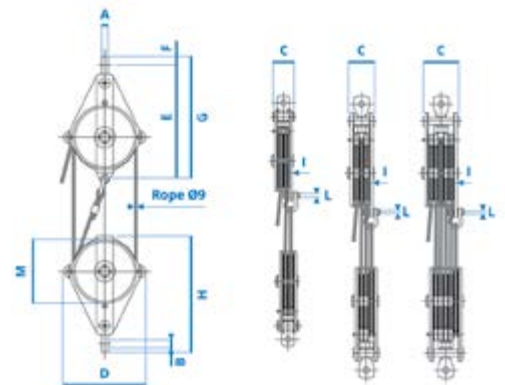

Part No.	Working Load (m)											Pulling Force/ Lifting Load	Working Load (kN)	Wt (kg)
	A	B	C	D	E	F	G	H	I	L	M			
TAP001	22	20	67	242	333	20	353	331	8	10.5	180	1:4	30	17
TAP010	22	23	85	294	380	28	408	386	10	16	180	1:6	50	27
TAP020	22	26	120	294	405	35	440	415	10	10.5	180	1:10	80	42

Suitable rope FUZ009 (diameter 9mm). Suitable swivel GGT001

### Hand Line Blocks

#### Part No. Various



- Hand rope blocks used for hauling and lifting
- Made of high strength aluminum alloy
- Side gate opening with detent pin
- High strength steel rotating swivel hook with safety latch
- Free running sheaves with shielded bearings

Part No.	Max Rope Ø (mm)	Sheave Size (mm)	Wt (kg)	WLL (kg)
SPP-HLB	14	75	1.4	560
AHB-4	22	100	2.8	1130

### TESMEC

#### Zoom Sag Scope - TESMEC

Part No. TGP001

- Suitable for accurate conductor sag measurements.
- Equipped with a special anchoring support for steel tower.



#### Thermometers - TESMEC

Part No. TET060

The thermometers are made of an aluminium bulb reproducing the conductor's surface.



Part No.	Length (m)	Wt (indicative) (kg)
TET060	0.49	0.6 to 1.0

Diameter "d" of the conductor to be specified

#### Cover Joints - TESMEC

Part No. PG Series

The cover joints are specifically designed to protect the mid span joint, made at the "tensioner station", during conductor stringing operations.

The cover joints consist of two shells made of galvanized steel with shaped ends to house the rubber noses, which protect the mid span joint during the passage over the pulleys. The shells are coupled together by socket screws and the rubber noses are clipped together by belts.

Following data to be specified

- 1) Joint length after compression
- 2) Conductor diameter
- 3) The hexagon dimension of mid span joint after compression



Part No.	Length (m)	CH max (mm)	Max Dia (mm)	L Max (STD) ** (mm)	Working Load * (at the edges) (kN)
PGC	For pulley with 54 mm groove	28	18	600	2.5 to 5.0
PGS	For pulley with 68 mm groove	37	25	1000	4 to 6.5
PGM	For pulley with 68 mm groove	48	31.5	1050	2.0 to 5.0
PGL	For pulley with 95 mm groove	56	47	1300	Max 6.5
PGX	For pulley with 130 mm groove	82	54	2000	5.0

\* Changes with length \*\* different lengths are available upon request

Refer Hydraulic Section for  
Tesmec 100T Press  
Part No. PRT510



### EPZ - (Equipotential Zone)

#### Rolling / Running Earths

##### Part No. Various

- Consider Conductor OD & Fault Current Rating
- Earth Leads available on request
- Ideal for stringing and re-conductoring



9738  
\*Lead not Included



MTR052  
Lead Included



A78000  
\*Lead not Included

Part No.	Description	Conductor OD (mm)	Download	Fault Rating (kA/sec)	Manufacturer
MTR052	Stringing Earth	Max 70	6m x 50mm <sup>2</sup> CU	10/0.4	Tesmec
9738	Stringing Earth	4.1 to 28.5	*Sold separately	19.1/.05	Hastings
78000	Stringing Earth	3 to 41		25/0.5	Salisbury
A78000	Stringing Earth with 2 earth studs	3 to 41		25/0.5	Salisbury

\*Contact TEN for your earth lead requirements

### Equipotential Earth Mats - Kri-Tech

##### Part No. Various

The Kri-Tech Bond Mat System is designed and high voltage tested to protect workers who come in contact or have the potential for electrical contact.

- Establishes temporary equipotential zone during energised and de-energised work practices
- Portable, versatile and lightweight
- Prevents workers from being exposed to hazardous differences in electrical potential
- Non-slip black matting also available - ideal for use in wet environments

- Manufactured from high amperage tinned copper braid sewn into grid pattern onto vinyl/polyester fabric
- Suitable for a wide range of applications including:
  - Making cable terminations on transformers and in cubicles
  - Opening or closing overhead air breaks
  - Working on control boxes of regulators, reclosers, capacitors, pad mounted switches
- Stringing Operations



Black Non-Slip Mat

Part No.	Size (m)	Colour	Description
KTMNS5-5-1.5NT-A	1.5 x 1.5	Black (Non-slip)	Earth, mat, equipotential, 1.5m lead term to Screwdriver Clamp, Kri-Tech
KTM5-5-1.5NT-A	1.5 x 1.5	Orange	Earth, mat, equipotential, 1.5m lead term to Screwdriver clamp, Kri-Tech
KTM1010-2X1NT-A	3.0 x 3.0	Orange	Earth, mat, equipotential, 2 x 1m leads term to Screwdriver clamp, Kri-Tech

Custom Sizes & Non-terminated Options available on request

Range of Stringing Earths (PEDs) available - Refer to Earthing, Jumpers and Switches section for further information



Refer Storage Section for further information on Storage Bag options

#### Custom Stringing Machine Layouts Available







### PEDs - Portable Earthing Devices

Commonly known as "Earth-sets, Earth-sticks, Earthing Devices, Portable Earthing Devices or PED's". These devices attach temporarily to de-energised conductors or contact points and a known earth.

PED's are safety devices that are type tested and manufactured to withstand the maximum fault current for the specific portion of the network being worked on in the event that the conductor or contact point becomes energised.

PED's are designed so that they provide enough time, usually several milliseconds to carry fault current long enough for a circuit breaker or fuse to interrupt the flow of current. Consult your local network or asset owner for applicable legislative requirements.



SCAN or CLICK the QR-Code to download the PED order form

### Stick Kits - Hastings

#### Shotgun Stick Kit

##### Part No. 81-544

Hastings Shotgun sticks offer:

- Precision cast slide gives complete control and extra firm grip
- Full open side hook offers unobstructed view
- Hanger hook moulded into head
- Foam filled fibreglass main shaft
- Tested to ASTM F711 & OSHA
- Fixed shotguns tested to IEC 60855
- Solid fibreglass operating rod with guide
- Non-conductive polycarbonate head
- Customised versions available
- Hook release trigger shielded to avoid accidental operation
- Complete selection of fixed or sectional shogun kits available
- Complete range of adaptors and accessories and cleaning products



Refer to Fibreglass Equipment section for further information for a range of insulated sticks, kits & adaptors



Part No.	Length of Sections (mm)	No of Sections	Operating Lengths (m)	Description	Wt (kg)
81-544	1200	4	1.5 - 2.7 - 3.9 - 5.2	Sectional shotgun stick package complete with base, head, intermediate sections and carry case	7.1

#### Sectional Stick Kit

##### Part No. TENK010

- Customised stick kits made to customer specification or specific utility industry kits
- Below examples of Transmission Services kit



Component Part No.	Item Description	Qty in Kit
552-4	Stick Sectional Base 1.2m, 32mm OD	1
546-4	Stick Sectional Extension 1.2m, 32mm OD	3
A10012	Adaptor Male Universal Head 32mm	1
A30002	Hand Guard to Suit 32mm	1
AD06	AL Adaptor, 32mm Male Button to Female bayonet	1
RAWW176	Hand Cleaning Towelette - Disposable	5
10-188-1	Disposable Silicon Cleaning Wipe	5
10-090	Silicon Wiping Cloth	2
TENM302	Bag Sectional Kit, 4 x 1.2m & Acc Pock	1

## Conductor Triple Line Lifters - LineWise

The phase lifters are an insulated crane attachment used to support up to three energised lines. The Triple Line Lifter replaces the need for temporary structures and tag lines while giving positive control of the live lines.

### Features

- Hydraulic articulation, extension & retraction
- Quick Attach Insulators & Wire Holders
- Insulators lab tested
- Vertical and horizontal construction
- High Strength Steel fabrication
- Holding valves on all cylinders
- Manual override control valve
- Handheld Radio Remote Control
- Installed at Earth level
- Supplied with transportation storage skid and compartments for insulators, wire holders and pins

### Triple Line Lifter - Max 1770kg

#### Part No. TLL-1300

The Triple Line Lifter 1300 is an insulated crane attachment used to support up to 3 energised lines. The TLL-1300 has a maximum capacity of 590kg per phase with a total capacity of 1770kg.

- For Transmission voltage from 66 to 220kV
- Conductor spacing: 1.98 –4.42m
- Unit weight: 1340kgs
- Mounted in skid: 1680kgs

Voltage (kV)	Conductors	Phase spacing Max (mm)	Phase spacing Min (mm)	Capacity per phase / total (kg)
66	3	8939 Outside-Outside	3962 Outside-Outside	590/1770
110	3			590/1770
132	3	4420 Centre - Outside	1981 Centre - Outside	544/1633
220	3			Consult

### Triple Line Lifter - Max 3408kg

#### Part No. TLL-2500

The Triple Line Lifter 2500 is an insulated crane attachment used to support up to 3 energised lines. The TLL-2500 has a max capacity of 1136kg per phase with a total capacity of 3408kg.

- For Transmission voltage from 110 to 330kV
- Conductor spacing: 3.05 –7.3m
- Unit weight: 2730kgs
- Mounted in skid: 3410kgs



Handheld Remote

Voltage (kV)	Conductors	Phase spacing Max (mm)	Phase spacing Min (mm)	Capacity per phase / total (kg)
110	3	14630 Outside-Outside	6096 Outside-Outside	1136/3408
132	3			1136/3408
220	3	7315 Centre - Outside	3048 Centre - Outside	1136/3408
330	2			2270



Vertical and horizontal configurations



TLL-1300 Packed for transport



Vertical and horizontal configurations



TLL-1300 Packed for transport

## NOTES

A series of horizontal dotted lines spanning the width of the page, intended for handwritten notes.





## NOTES

A series of horizontal dotted lines spanning the width of the page, intended for taking notes.



## TEN Group

The Energy Network (Australia) Pty Ltd | ABN 72 093 052 441

### QUEENSLAND

2B, 605 Zillmere Road  
ZILLMERE 4034

**P** +61 7 3212 8999

**W** [www.tengroup.com.au](http://www.tengroup.com.au)

**E** [salesqld@tengroup.com.au](mailto:salesqld@tengroup.com.au)

### TEN HIRE

2B, 605 Zillmere Road  
ZILLMERE 4034

**P** +61 7 3212 8999

**W** [www.tenhire.com.au](http://www.tenhire.com.au)

**E** [hire@tengroup.com.au](mailto:hire@tengroup.com.au)

### NEW SOUTH WALES

Suite F2, Level 1  
152-156 Pacific Highway  
TUGGERAH NSW 2259

**P** +61 417 631 443

**E** [salesnsw@tengroup.com.au](mailto:salesnsw@tengroup.com.au)

### VICTORIA

Unit 16, 191-195 Greens Road,  
DANDENONG STH VIC 3175

**P** +61 3 9793 1622

**E** [salesvic@tengroup.com.au](mailto:salesvic@tengroup.com.au)

### WESTERN AUSTRALIA

4/15 Baile Road  
CANNING VALE WA 6155

**P** +61 8 9455 5574

**E** [saleswa@tengroup.com.au](mailto:saleswa@tengroup.com.au)

### TASMANIA | STH AUSTRALIA

Unit 19, 15 Stanton Place  
CAMBRIDGE TAS 7170

**P** +61 499 996 441

**E** [salestas@tengroup.com.au](mailto:salestas@tengroup.com.au)

